

1996

# Systematic Configuration of Robotic Locomotion

Dimitrios Apostolopoulos  
*Carnegie Mellon University*

Follow this and additional works at: <http://repository.cmu.edu/robotics>

 Part of the [Robotics Commons](#)

---

This Technical Report is brought to you for free and open access by the School of Computer Science at Research Showcase @ CMU. It has been accepted for inclusion in Robotics Institute by an authorized administrator of Research Showcase @ CMU. For more information, please contact [research-showcase@andrew.cmu.edu](mailto:research-showcase@andrew.cmu.edu).

# **Systematic Configuration of Robotic Locomotion**

Dimitrios Apostolopoulos

CMU-RI-TR-96-30

The Robotics Institute  
Carnegie Mellon University  
Pittsburgh, Pennsylvania 15213

July 26, 1996

© 1996 Dimitrios Apostolopoulos & Carnegie Mellon University

This research was sponsored by NASA under grant NAGW-3863. The views and conclusions contained in this document are those of the author and should not be interpreted as representing the official, either expressed or implied, of NASA or the United States Government.

---

# Abstract

Configuration of robotic locomotion is a process that formulates, rationalizes and validates the robot's mobility system. The *configuration design* describes the type and arrangement of traction elements, chassis geometry, actuation schemes for driving and steering, articulation and suspension for three-dimensional motions on terrain. These locomotion attributes are essential to position and move the robot and to negotiate terrain. However, configuration of robotic locomotion does not just involve the electromechanical aspects of design. As such, configuration of robotic locomotion should also be responsive to the issue of *robotability*<sup>TM</sup>, which is the ability to accommodate sensing and teleoperation, and to execute autonomous planning in a reliable and efficient manner. Furthermore, configuration should address reliability by introducing and implementing margins to account for initial underestimates of mass, power, and mobility.

In this technical report we formulate a framework for systematic configuration of robotic locomotion to facilitate designs appropriate for execution of robotic functions. Emphasis is placed on the analysis of configuration requirements, mapping between the configuration requirements and locomotion subsystems, and analysis for evaluating fundamental configurations. We implement the framework on the locomotion configuration of a lunar robot and its terrestrial prototype.

---

# Contents

<b>Introduction</b> .....	<b>1</b>
State-of-Practice	1
Shortfall of State-of-Practice and Motivation	2
Elements of Systematic Configuration of Robotic Locomotion	3
<b>Related Research</b> .....	<b>4</b>
Configuration Design of Mobile Robots	4
Engineering Design Methods	5
<b>The Framework</b> .....	<b>7</b>
From Problem Specification to Configuration Requirements	7
Mapping Configuration Requirements to Robotic Locomotion	13
Fundamental and Detailed Configuration	18
Summary and Contributions	22
<b>References</b> .....	<b>24</b>
<b>Appendix: Mobility Analysis</b> .....	<b>28</b>
Sinkage	29
Motion Resistance	31
Drawbar Pull	36
Drive Torque and Power	38
Slope Negotiation	41

---

# Chapter 1

## Introduction

The importance of locomotion to the capability of a mobile robot is paramount. The locomotion system generates traction, negotiates terrain, positions and moves the robot. It can also be used to stabilize the vehicle's frame and smooth the motion of sensors and computing hardware for autonomous navigation. The configuration design of robotic locomotion affects the difficulty of motion control and automatic planning. Some locomotors can pose body attitude and react to the forces developed by task tools such as manipulators, backhoes, and coring devices. Practically, every aspect of the performance of a mobile robot relates to its locomotion configuration.

---

### State-of-Practice

In general, the state-of-practice is to configure the locomotion system based on knowledge of precedent robotic and conventional vehicle designs, and loose intuition. Many designers rely on experience to understand the critical issues involved and to develop configurations appropriate for the assigned task. Generation of configuration variants (topologies) is based on brainstorming and modification of existing vehicle designs. It is also common practice to analyze and iterate configuration during design, with the expectation that analysis and subsystem testing will reveal configuration deficiencies.

Traditionally, configuration of robotic locomotion is used to produce robot designs with adequate mobility. Issues of motion control and navigation are deferred until after the vehicle design is complete, when sufficient knowledge of the physics and kinematics of the robot exists. Very few robotic developments have utilized parametric studies and

simulation to quantify and evaluate locomotion configurations beyond basic mobility capabilities.

---

### Shortfall of State-of-Practice and Motivation

Empirical approaches to configuration of robotic locomotion fail to address the dominant issues of, and relationships between, the robot's form and function. Experience could help identify key issues, such as what is the appropriate traction and suspension scheme for an autonomous excavator. Unfortunately, robots are complex engineering artifacts and it is only when the robot is fully developed and tested that critical performance metrics become apparent and configuration deficiencies are realized. Configuration that achieves incomplete coverage of the issues leads to deceptive estimates of vehicle parameters, and complicates design with lengthy iterations and significant systemic changes during development. Faulty configuration decisions could lead to programmatic and financial disasters.

Configuration of robotic locomotion as it is performed today does not take into account the relationships among locomotion, planning, and control. This is partially due to the fact that those relationships are only weakly understood. For instance, it is not fully clear how a locomotion configuration affects terrain sensor requirements. Another example is the relationship between the detail of mechanism models and control complexity. The need is for configuration that allows straightforward modeling with linearizable and controllable dynamics. Problems occur when the configuration defies simplified accurate models needed for planning and control.

An issue that has not been addressed in the current practice of robotic locomotion configuration is that of establishing configuration margins to accommodate growth in mass and volume during design, and to cope with development contingencies. It is usually during the detailed design that structural margins are imposed to assure safe operational capability of components and assemblies. In practice, technical and programmatic failures occur not only because of failure of physical components, but also because of the inability of the selected locomotion configuration to operate with some margins in challenging situations.

Despite numerous developments of mobile robots the role of locomotion to the functionality and performance of the robot has not been fully characterized. The inefficiency of empirical approaches to provide rigorous and efficient methods for locomotion configuration and to quantify the relationships between *mobility*, *terrainability*, and *robotability* motivates the need for a new approach.

---

## Elements of Systematic Configuration of Robotic Locomotion

A new, more rigorous practice in configuration of robotic locomotion should:

- Generate classes of configuration requirements appropriate for robotic applications.
- Establish quantitative mapping between configuration requirements and locomotion subsystem functions.
- Create configuration topologies in a methodological fashion.
- Combine analysis and simulation to predict the performance of locomotion configurations.
- Introduce and implement quantitative robotic metrics to evaluate the configuration topologies.
- Detail the most promising configuration topology/ies and optimize until a rationalized configuration design is achieved.

We develop a framework of systematic configuration responsive to these issues. The framework will be used to configure *wheeled robotic locomotion for lunar exploration* as the archetype for rovers facing barren terrain with the added challenges of vacuum, cold, radiation and electrostatic dust, along with tough logistical constraints. By addressing issues of robot configuration for lunar excursions, a significant amount of understanding will be gained for other robotic applications.

---

## Chapter 2

### Related Research

A few application-specific mobile robot configuration studies can be found in the literature. Design methodologies from traditional engineering disciplines could support the development of a framework for systematic configuration of robotic locomotion.

---

#### Configuration Design of Mobile Robots

Research in planetary robotics has partially addressed the problem of configuration of robotic locomotion. Martin Marietta Space Systems Company [MMSSC88], [Spiessbach88], the Jet Propulsion Laboratory [JPL87], and the Boeing Company [Boeing92] have performed configuration studies of planetary rovers. Martin Marietta's study of Mars rovers represents a taxonomy of mobility options and enumerates feasible locomotion topologies [MMSSC88]. Design decisions are based on criteria of functionality and maturity of technology. Other studies summarize performance metrics for evaluating locomotion of planetary rovers and suggest mobility reference models to streamline the design process [JPL87]. Hirose searches for universal performance metrics to enable comparison of different locomotion schemes based on physical principles [Hirose91]. Most of these studies, though useful in that they recognize the need for analytical configuration, fail to address how parametric analysis could be used in configuration. The majority of the methods used rely on function-based studies of configuration that do not support rationalization of the process and quantification of configuration topologies. Studies that introduce metrics of performance and suggest parametric analysis do not demonstrate how performance metrics could be used to bound configuration and dimension topologies. The biggest deficiency is that these studies do not address any relationships between locomotion



configuration and robotic functions, such as autonomous planning and terrain perception.

Bares introduces the idea of credible and rational system design in the development of mobile unmanned work systems [Bares87]. This distinction is key to the design of prototype robots: the credible design is one that complies reasonably to system-level specifications, acknowledges peripheral system specifications and conforms to resource constraints. The rational design, which is derived from a credible design is composed of compatible rational systems and complies with system-level requirements. In his later work Bares addresses locomotion configuration of autonomous walkers for extreme terrain and establishes performance measures to evaluate configuration topologies [Bares91]. His approach to configuration involves geometric analysis of gaits and functional comparisons to determine the most appropriate configuration.

Waldron addresses the synergy of mechanics of a mobile robot, control and sensing, and the impact of their interaction to the performance of the robot [Waldron 85-1]. He uses the notions of actuated degrees-of-freedom, mobility, sensing and coordination to characterize locomotion configurations. Based on the concept of preferred direction of operation locomotion configuration impacts the geometric form of the vehicle and the symmetry of its body. The terrain behavior of a field robot is characterized by its ability to scale small amplitude random terrain variations and to negotiate large obstacles. Waldron introduces the metric of response power spectral density to evaluate vehicle performance subjected to small terrain variations and two-parameter obstacles to quantify locomotion performance on large terrain variations.

Littmann has implemented parametric simulation to evaluate the terrainability of wheeled planetary rovers. Studies of obstacle climbing capability of wheeled vehicles demonstrate the role of analysis in configuration of robotic locomotion [Littmann92].

---

## Engineering Design Methods

The development of a systematic framework for robotic locomotion can leverage on existing research in methodological engineering design. In the past few decades European and American schools of design have developed methodological design techniques for systematizing the design process with the purpose of improving engineering practice and products. Their focus has been to develop methods for creating functional descriptions of technical systems, generating and evaluating alternatives, and detailing conceptual designs, [Jones70], [Hubka88], [Kannapan87-1/2], [Koller76], [Pahl84], [VDI87] to site a few.

Cross motivates the need for systematic procedures to design complex engineering prototypes with high development risks and cost constraints and describes the steps to rational design methods [Cross89]. Clarifying objectives is the first part of the process. Cross implements functional analysis to break down the structure of the system and

specifies requirements for each performance attribute. He also utilizes morphological charts and the weighted objectives method to generate and evaluate variant configurations respectively.

Beitz characterizes engineering systems based on functional, working, construction and systemic interrelationships [Beitz87]. His classification defines the limits of each step in the design process and can be directly implemented on the configuration of robotic mechanisms. Pahl and Beitz developed a detailed model of the design process that utilizes function structures to capture form and function of the designed system [Pahl84]. Pahl and Beitz's method generates topologies by synthesizing solution principles of the fundamental functions. Functionality and maturity of the working principle are two of the key criteria for evaluating configurations. Their work has been successful in creating conceptual designs of electromechanical assemblies.

Roth introduces a hierarchical representation of configuration which takes a functional structure and physical effects and transforms them to a working contour with the aid of cybernetical and physical principles, vectorial functions and contact matrices [Roth87]. To detail configuration ontologies, he introduces relationships of contacting surfaces and working bodies.

Koller distinguishes among function, qualitative, and quantitative synthesis in conceptual design [Koller76]. Function synthesis yields representations of physical and logical relationships between mechanical subsystems. Koller's techniques can be used to analyze and evaluate topologies at different levels of abstraction.

Hubka has developed a theory of technical systems [Hubka88]. He addresses the issues of complexity, resolution, and representation in design and classifies technical systems based on these issues. He introduces scleronomic, rheonomic, holonomic, and non-holonomic properties to characterize technical systems. The technique of mathematical processing of single values to a total value is useful to quantify compound indices of performance of robotic locomotion. He also points out that a complete performance index should take into account causal relationships and functional dependencies.

---

## Chapter 3

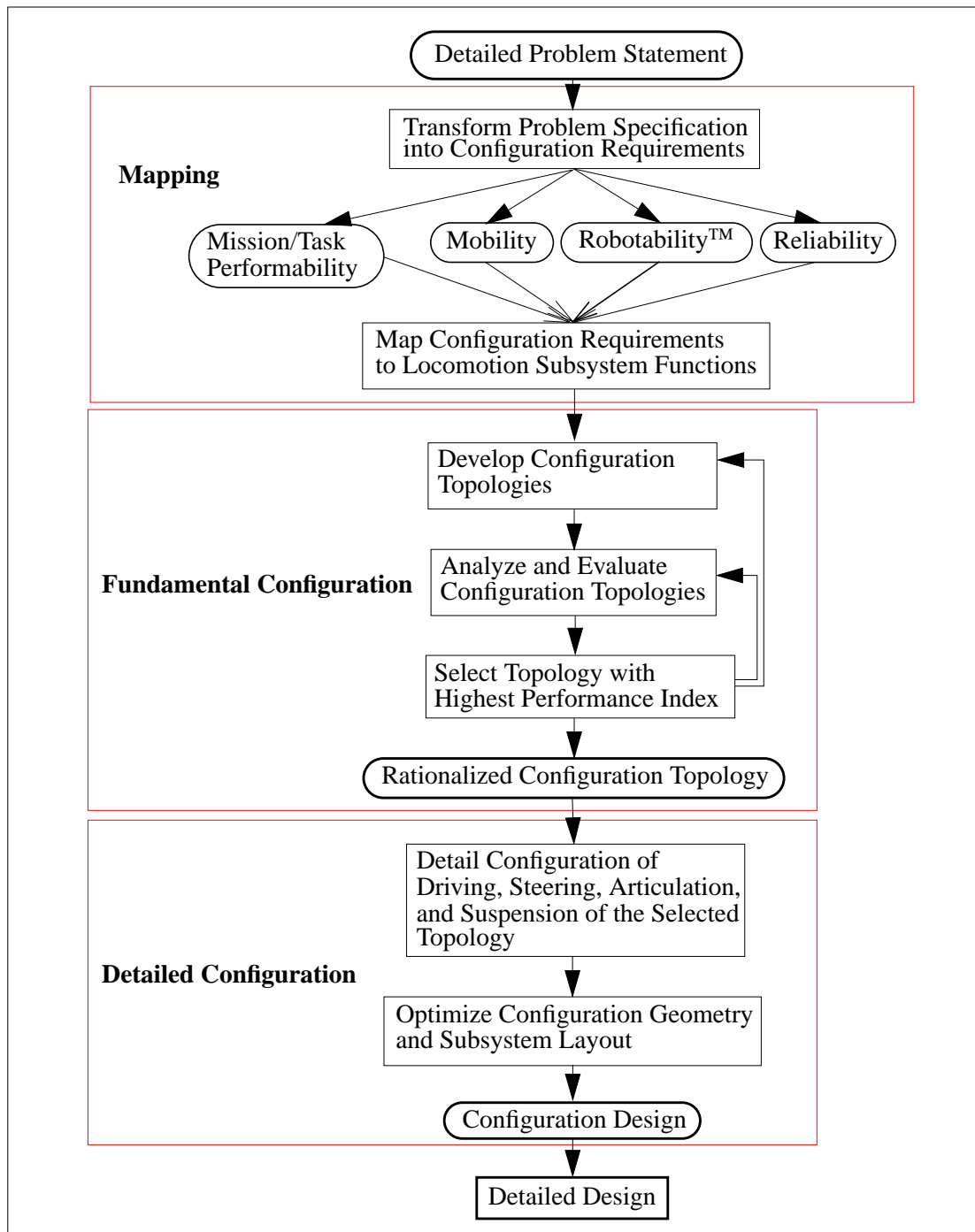
# The Framework

The proposed framework is a procedure that utilizes rational methodological design, parametric and dimensional analysis, and optimization to synthesize and detail robotic locomotion. The framework consists of **mapping** between configuration requirements and the functions of robotic locomotion, **fundamental configuration** where locomotion topologies are synthesized, analyzed and predictions of their performance are made, and **detailed configuration** where a rationalized configuration topology is further analyzed and its geometry and subsystem layout are optimized. A prescriptive model of the framework is shown in Figure 3-1. The purpose of the flowchart is to make explicit the hierarchy and relationships between the various configuration tasks. In our view, configuration encompasses all the engineering effort that goes into a robotic system development from the moment that a problem specification is formalized until the detailed design of components begins. We present the tasks involved in each of the three configuration phases, namely mapping, fundamental and detailed configuration.

---

### From Problem Specification to Configuration Requirements

Systematic configuration begins by classifying the functional and performance specifications defined in the detailed problem statement (“problem” refers to the robotic mission or task) into classes of configuration requirements [Bares87], [Larminie88]. There are four classes of configuration requirements, each one of which relates to a distinct aspect of the expected robotic performance: mission/task performability, mobility/terrainability, robotability, and reliability. Refer to [Apostolopoulos91-2] for a detailed description of the classification process.



**Figure 3-1:** The proposed framework for systematic configuration of robotic locomotion.

The classification process results to *Configuration Requirement Templates (CRTs)*, which are lists of metrics that detail the robot's expected performance in relation to each one of the aforementioned classes of configuration requirements. The CRT for Mission/Task Performability is different for each robotic application. CRTs for

mobility and robotability incorporate similar metrics for a wide variety of robotic applications. The CRT is a means of making explicit the dependencies between *locomotion configuration* and *robotic performance* and facilitate the mapping between requirements and locomotion which is described in the following section.

Mission/task performability requirements are constraints imposed by the “environment” of operation or the task to be performed. The term “environment” is broadly used and it means any natural or technical system that interfaces with the robot throughout its operational life.

*Case Study: Configuration of Robotic Locomotion for Lunar Exploration.*

The Lunar Rover Demonstration program at Carnegie Mellon University has configured lunar robots and addressed some of the key aspects of robotic operations on the moon, including issues related to mobility, control architecture, telemetry and imagery. Of key importance to the success of the mission is the capability of the rover’s locomotion system to reliably traverse one thousand kilometers of unknown terrain over two years. The intended mission involves soft landing two rovers near the Apollo 11 site. From there, the rovers will navigate under human teleoperation and autonomous safeguarding to regions that have been visited by previous exploratory missions, such as the landing sites of Apollo 17 and Lunakhod 2. During the traverse the rovers will provide real-time, high-resolution panoramic imagery of the lunar terrain and unique views of each other traversing the lunar surface. Throughout the traverse, commercial sponsors and scientists will share command of the rovers, while the public will participate through interactive theme parks and tele-networks. It is therefore required that the rovers must safely allow teleoperation by semi-skilled operators on Earth. A complete description of the mission and robot design can be found in [Whittaker95-1/2]. Relevant planetary rover developments are described in [Amai93], [Bickler92], [Burke92], [Carrier92], [Price90], [Hoffman92], [Kemurdjan92/95], [Wong68].

In the case of the lunar robot, the mission/task performability requirements involve issues such as integrating the robot with the lander vehicle, survivability in the hard vacuum, radiation, dust and temperature extremes of the lunar environment, etc. Table 3-1 illustrates how a CRT is constructed. Tasks to be performed are described in the performability specification. For each task there is a list of quantitative or qualitative metrics in the form of configuration requirements that relate to the task specification.

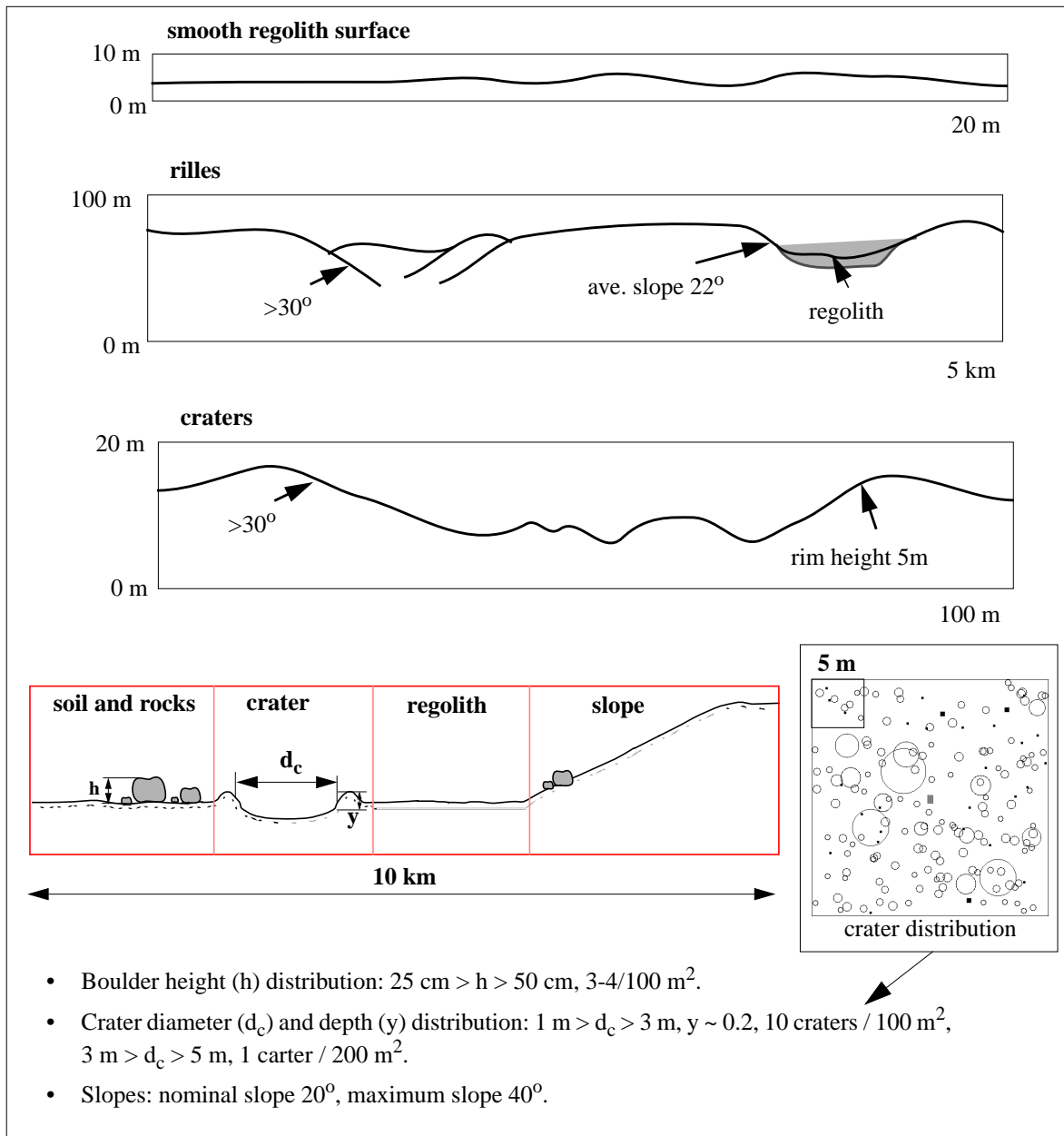
<u>Mission/Task Performability Specification</u>	<u>Robot Configuration Requirements</u>
LRI Mission Definition Specifics	Examples
Interface robotic payload (two rovers) to the Phobos-class Lander [Whittaker95-1]: <i>mass, volume, stowing configuration, payload attachments, etc.</i>	<ul style="list-style-type: none"> <li>- Robot mass less than 250 kg (550 lbf)</li> <li>- Robot can fit in the Proton payload volume: cylinder 3.8 m ID (12'6"), 3.3 m (11') height.</li> <li>- C.G. of the robot less than 1 m from stowed position (Figure 3-4).</li> </ul>
Launch robotic payload: <i>launch shock, inertial and gravitational effects, dynamic vibrations.</i>	<ul style="list-style-type: none"> <li>- Stowed rover(s) sustain loads due to:               <ol style="list-style-type: none"> <li>1. maximum axial acceleration: +6 g's</li> <li>2. maximum lateral acceleration: +/-3 g's</li> <li>3. maximum shock of 2500 g's @ ~2K Hz.</li> </ol> </li> </ul>
Transport robotic payload to the lunar surface: <i>transfer loads, thermal excursions, etc.</i>	<ul style="list-style-type: none"> <li>- Sustain thermal environment of the payload fairing.</li> </ul>
Descent and touchdown lander and robotic payload: <i>landing impact, detaching from lander, drive off lander.</i>	<ul style="list-style-type: none"> <li>- Stowed rover(s) sustain impact loads due to:               <ol style="list-style-type: none"> <li>1. vertical landing velocity: 2 m/sec.</li> <li>2. horizontal landing velocity: 1.2 m/sec.</li> </ol> </li> <li>- Rover should be shielded during landing.</li> </ul>
Rover(s) traverse(s) lunar surface.	<ul style="list-style-type: none"> <li>- Mobility/terrainability CRT</li> </ul>
Rover(s) survive(s) lunar environment: <i>electrostatic dust, thermal excursions, vacuum, radiation.</i>	<ul style="list-style-type: none"> <li>- Mitigate electrostatic dust accumulation:               <ol style="list-style-type: none"> <li>1. limit exposed moving parts,</li> <li>2. minimize points that need to be sealed.</li> </ol> </li> <li>- Mitigate thermal effects:               <ol style="list-style-type: none"> <li>1. reduce exposed mechanical assemblies,</li> <li>2. select monocoque-type structures,</li> <li>3. prefer convex shapes for structural surfaces.</li> </ol> </li> </ul>

**Table 3-1:** CRT for Mission/Task Performability requirements of CMU's lunar robot.

Mobility and terrainability requirements relate to the locomotive performance of the robot and its ability to negotiate terrains. Mobility is characterized by metrics of driving, steering, braking and dynamic response [Turnage89], [Waldron85-1/2]. Performance on mild terrain relates to the capability of the vehicle to scale small-amplitude terrain variations and to negotiate obstacles of size comparable to the size of traction elements [Bekker56/64/69]. The mobile robot must step on and surmount vertical steps and ditches. In extreme terrain, physical obstacles have more than one significant feature and appear in random distributions. It is therefore necessary to consider the robot's ability to negotiate three-dimensional objects. Another key aspect of a mobile robot's terrainability is its maneuverability which is the ability to circumnavigate obstacles. Very frequently, the robot has to negotiate inclined terrain.

Slope gradability is characterized by the robot's ability to drive on downhill and crosshill slopes, over slope transitions, and in worst-case situations, to climb over obstacles superimposed on slopes.

To create the CRT for mobility and terrainability of a lunar robot, someone needs to extract the constraints and specifications that relate to the locomotive capability of the robot. A characterization of the lunar terrain that includes information of soil geophysical properties and statistical distributions of rocks and craters (Figure 3-2) is useful to quantify terrainability requirements (Table 3-2).



**Figure 3-2:** Characterization of lunar terrain useful to quantify the mobility/terrainability CRT [Heiken91].

<u>Mobility/Terrainability Specification</u>	<u>Robot Configuration Requirements</u>
Performance	Examples from CMU's LRI mission
Mobility: <i>speed, acceleration, braking distance, etc.</i>	<ul style="list-style-type: none"> <li>- Maximum speed: 0.75 m/sec.</li> <li>- Average speed: 0.30 m/sec.</li> <li>- Maximum acc/deceleration: 2 m/sec<sup>2</sup>.</li> </ul>
Trafficability in soft lunar soils (regolith): <i>sinkage, resistance, drawbar pull, torque, power.</i>	<ul style="list-style-type: none"> <li>- Maximum wheel sinkage 4 cm (1.6").</li> <li>- (Drawbar Pull)/(wheel load) ratio <math>\geq</math> Tan[average_slope].</li> <li>- Maximum contact pressure: 3 kPa (0.43 psi).</li> </ul>
Terrainability over scalable random terrain variations.	<ul style="list-style-type: none"> <li>- Maximum vertical dynamic transfer function: <math>VDTF \leq 1/4</math>.</li> </ul>
Terrainability over discrete terrain features: <i>step, ditch, obstacle.</i>	<ul style="list-style-type: none"> <li>- Maximum negotiable step: 30 cm (11.8").</li> <li>- Maximum negotiable ditch: 35 cm (13.7").</li> <li>- Minimum body clearance: 40 cm (15.7").</li> </ul>
Maneuverability through cluttered terrain.	<ul style="list-style-type: none"> <li>- Minimum distance between insurmountable obstacles: 5 m (16'4")</li> <li>- Minimum turning radius: 2 m (6'5").</li> <li>- Point-turn capability is desirable.</li> </ul>
Slope climbing: <i>downhill, cross-slopes, slope transitions.</i>	<ul style="list-style-type: none"> <li>- Rover should grade 30 deg downhill and 25 deg crosshill slopes.</li> <li>- Rover should be statically stable on 45 deg slopes.</li> </ul>
Terrainability over combined terrain features: <i>obstacle on a slope, combined slopes, etc.</i>	<ul style="list-style-type: none"> <li>- Rover should climb a 25 cm obstacle on a 15 deg slope.</li> </ul>

**Table 3-2:** Prototype CRT for mobility/terrainability.

Unique to a mobile robot are *robotability requirements*. Robotability™ is the ability of the locomotion system to accommodate sensing and to execute autonomous planning tasks and other robotic functions reliably and efficiently. We have already mentioned in the introductory chapter that state-of-practice does not address robotability issues in the configuration stages. Currently, issues of amenability to autonomous control and accommodation of terrain sensors are handled only after the electromechanism design of the robot is complete. In this framework we introduce a new idea: issues such as “optimal field of view without structural interferences” must be examined early in configuration and should be taken into account in dimensioning the locomotion system of the robot. We incorporate physics of sensing and kinematics of autonomous navigation in the parametric analytical evaluation of a locomotion configuration.



Robotic locomotion configuration should accommodate:

- Sensing without interferences.
- Terrain negotiation with minimal perception.
- Responsive execution of path planning.

These three issues partially address robotability. Robotability also relates to the teleoperability of a mobile robot. As of today, there are no rationalized metrics for selecting robotic configurations based on their potential to accommodate human teleoperation. The ability to perform incremental and reversible motions, decoupling of the primary propulsive and steering motions, axisymmetric chassis designs and equal terrainability in all directions are locomotion attributes that have an effect on robot teleoperability and should be quantified in configuration. A prototypical CRT for a lunar robot is shown in Table 3-3. It is evident that the performance specification and the configuration requirements are applicable to a wide range of mobile robot applications and configurations.

<b><u>Robotability Specification</u></b>	<b><u>Robot Configuration Requirements</u></b>
<b>Performance</b>	<b>Examples</b>
Sensing without interferences.	<ul style="list-style-type: none"> <li>- FOV of terrain sensors should not be obstructed by rover structures.</li> <li>- Propulsion, steering or suspension motions should not interfere with sensing hardware.</li> <li>- Terrain smoothing should minimize sensor vibrations.</li> </ul>
Terrain negotiation with minimal perception and planning.	<ul style="list-style-type: none"> <li>- Maximize terrainability with minimal control complexity. Minimize actuated DOF.</li> <li>- Limit or eliminate planned body posturing.</li> <li>- Maximize terrain coverage with minimal circumnavigation maneuvering.</li> </ul>
Responsive execution of path planning.	<ul style="list-style-type: none"> <li>- Minimum lookahead distance: 1.5 m (5')</li> <li>- Maximum lookahead distance: 3.5 m (11'5")</li> <li>- Minimum braking reaction time: 2 sec.</li> <li>- Maximum traveling speed: 0.75 m/sec.</li> </ul>

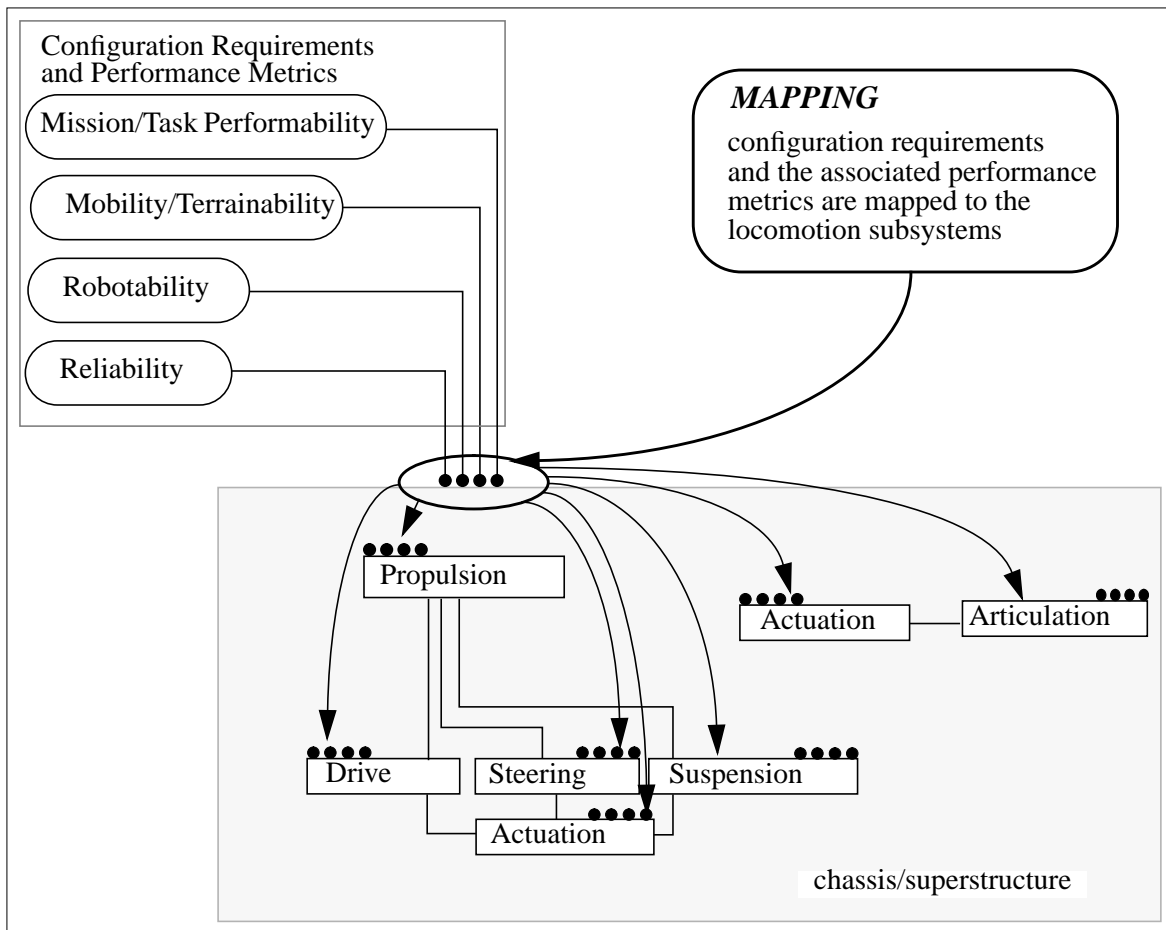
**Table 3-3:** CRT for robotability.

### Mapping Configuration Requirements to Robotic Locomotion

Classification of configuration requirements is followed by mapping the locomotion requirements to the subsystems of robotic locomotion. Mapping involves allocating requirements to locomotion functions and discovering analytical expressions or simple constraints which are necessary to quantify the relationships between CRT

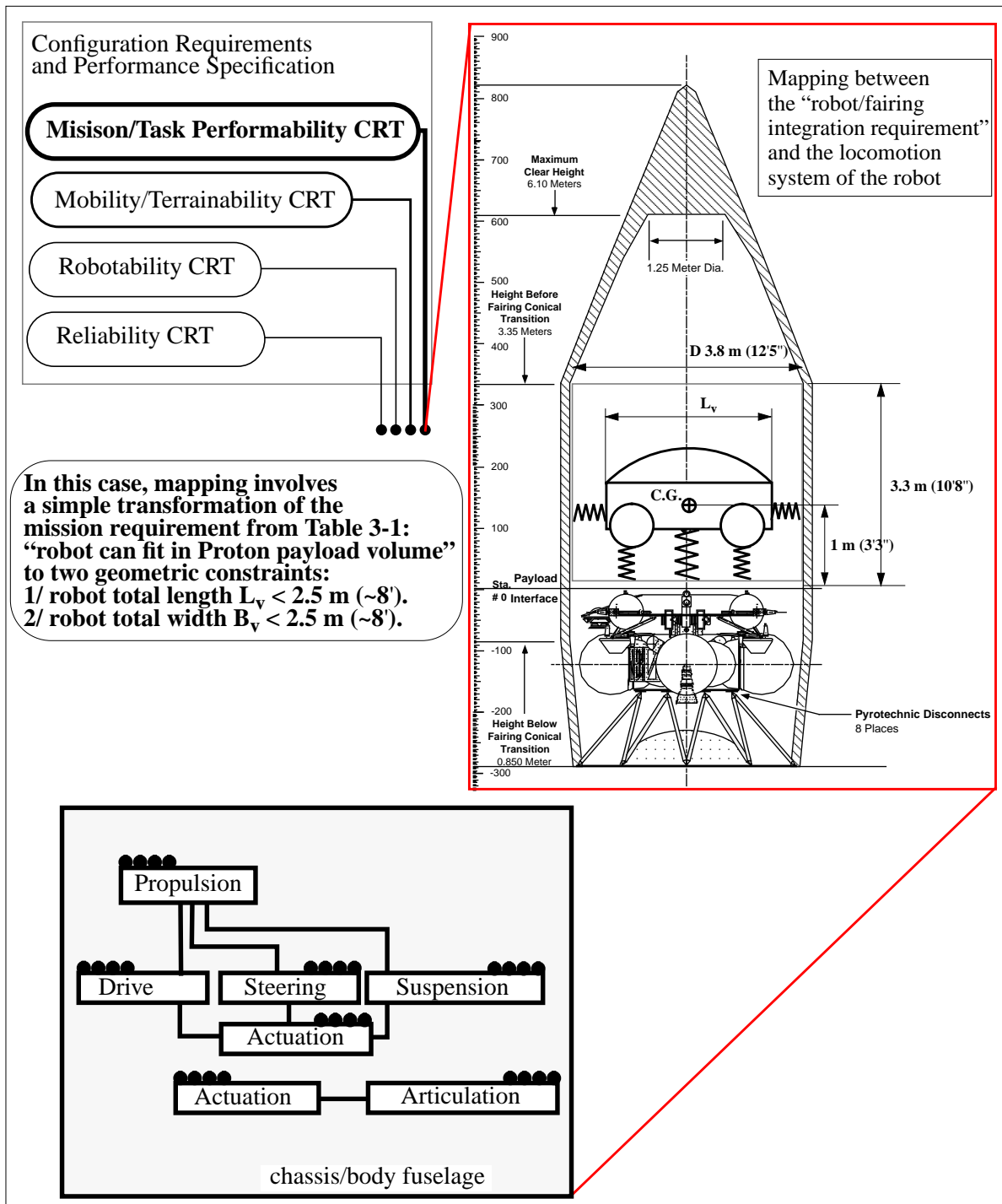
specifications and the locomotion configuration geometric and operational attributes. Configuration values such as wheel diameter, tire width, wheelbase, wheel stance, sensor mast height, drawbar pull, torque and power for driving a wheel, etc., are estimated based on parametric simulations of the equations relating the metrics under consideration (Figures 3-4/5/6).

Configuration requirements are mapped to the locomotion functions. A generic representation of locomotion includes the subsystems of propulsion, drive, steering, suspension, articulation and actuation. *Propulsion* is the subsystem that creates traction and moves the robot. The necessary torque and power are directed to the traction elements through the *drive* subsystem. Heading changes and maneuvering are performed by the *steering* subsystem, whereas *suspension* smoothens the effects of terrain irregularities on the robot. Locomotion functions are enabled by *actuation*. Actuation is necessary to drive and steer the robot, but suspension could be passive with no actuation involved. Common to robotic locomotion is *articulation*. Any form of articulation could assist body posturing and control of out-of-plane motions. *Chassis* and *body fuselage* connect the locomotion subsystems.

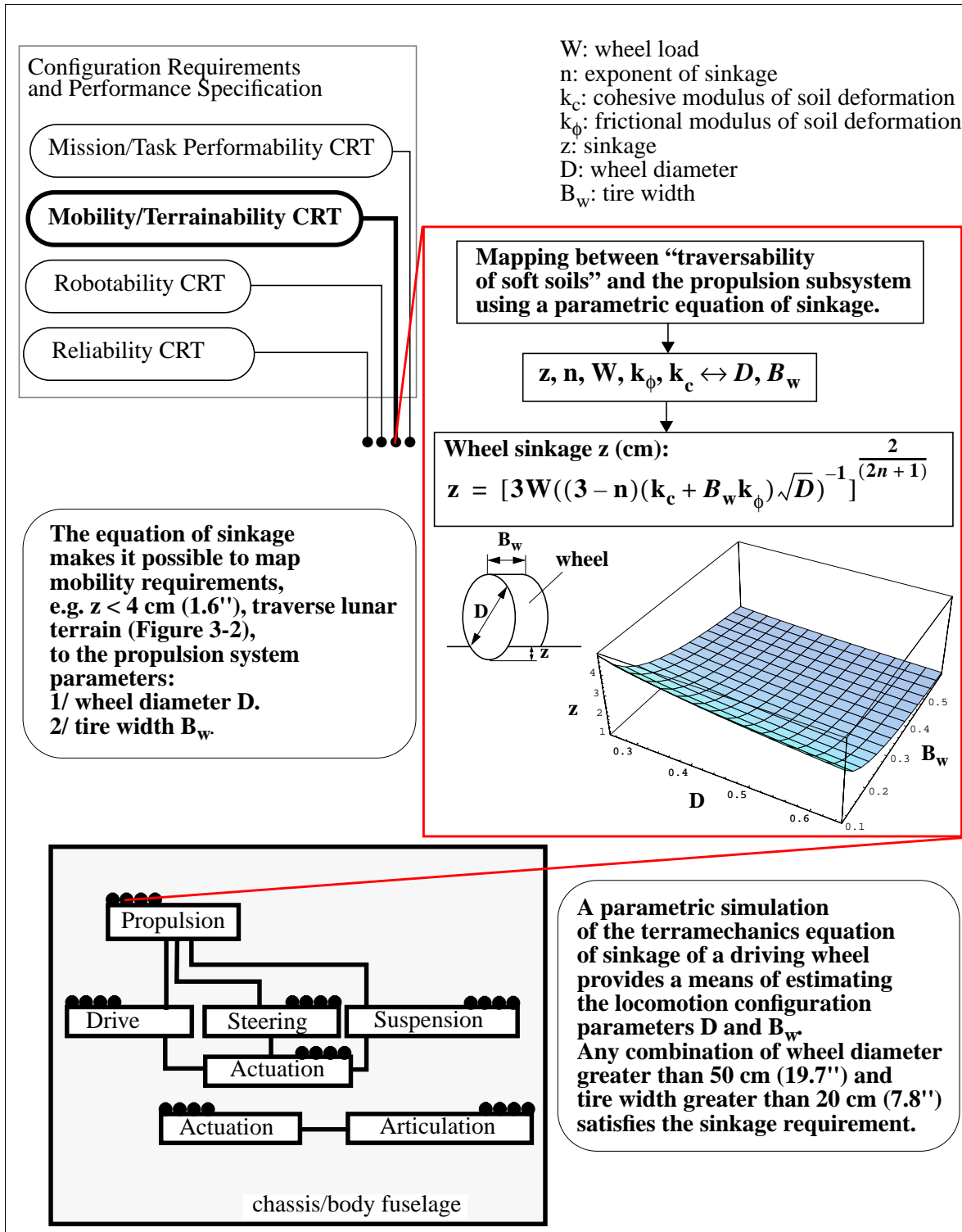


**Figure 3-3:** Mapping between configuration requirements and robotic locomotion.

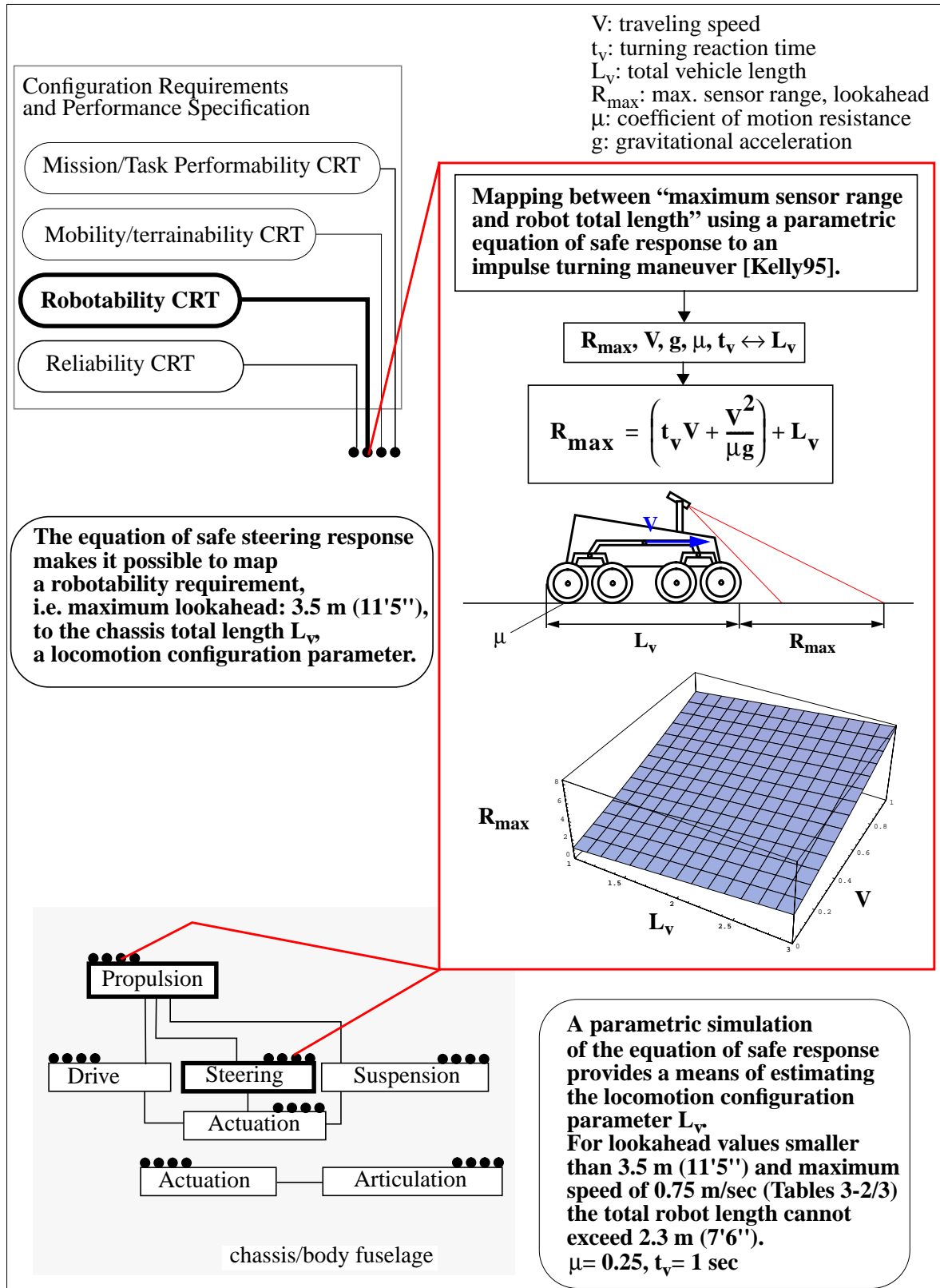
The following examples illustrate the mapping process:



**Figure 3-4:** Example of mapping between the Mission/Task Performability CRT and the locomotion system of the robot.



**Figure 3-5:** Example of mapping between the mobility CRT and the propulsion subsystem of the robot.



**Figure 3-6:** Example of mapping between the robotability CRT and the propulsion and steering subsystems of the robot.

---

## Fundamental and Detailed Configuration

*Fundamental configuration* transforms configuration requirements into credible locomotion topologies. A configuration topology is a description of the locomotion system of the mobile robot which contains the following information:

- Number and arrangement of propulsion elements.
- Drive scheme: number and placement of drive actuators, drive mechanism.
- Steering scheme: number and placement of steering actuators, steering mechanism.
- Suspension mechanism geometry and kinematics.
- Articulation mechanism geometry and kinematics.
- Chassis and body fuselage geometry and functionality.
- Function sharing between locomotion subsystems.
- Sensor mast geometry and placement with respect to the locomotion system.

In this phase we use parametric analysis to synthesize configuration topologies. A governing principle is that there are finite geometric and operational relationships between the locomotion subsystems and the chassis structure that define the form and function of configuration topologies. Form is defined as the geometry of three-dimensional parts, surface contours and contacts, linkages and connections. Function is described by motion, actuation and force paths. These primitive relationships assist function-based studies to create variant topologies. To bound the search for appropriate topologies we implement *parametric and dimensional analyses*: Parametric analysis facilitates the synthesis of locomotion topologies, whereas dimensional analysis produces quantitative metrics for evaluating configurations. For example, analytical equations of vehicle sinkage, power spectral density and power consumption for driving and steering could be combined to make decisions regarding wheel geometry and arrangement, chassis geometry and placement of drive and steering actuators. Fundamental configuration produces a small number of rationalized topologies.

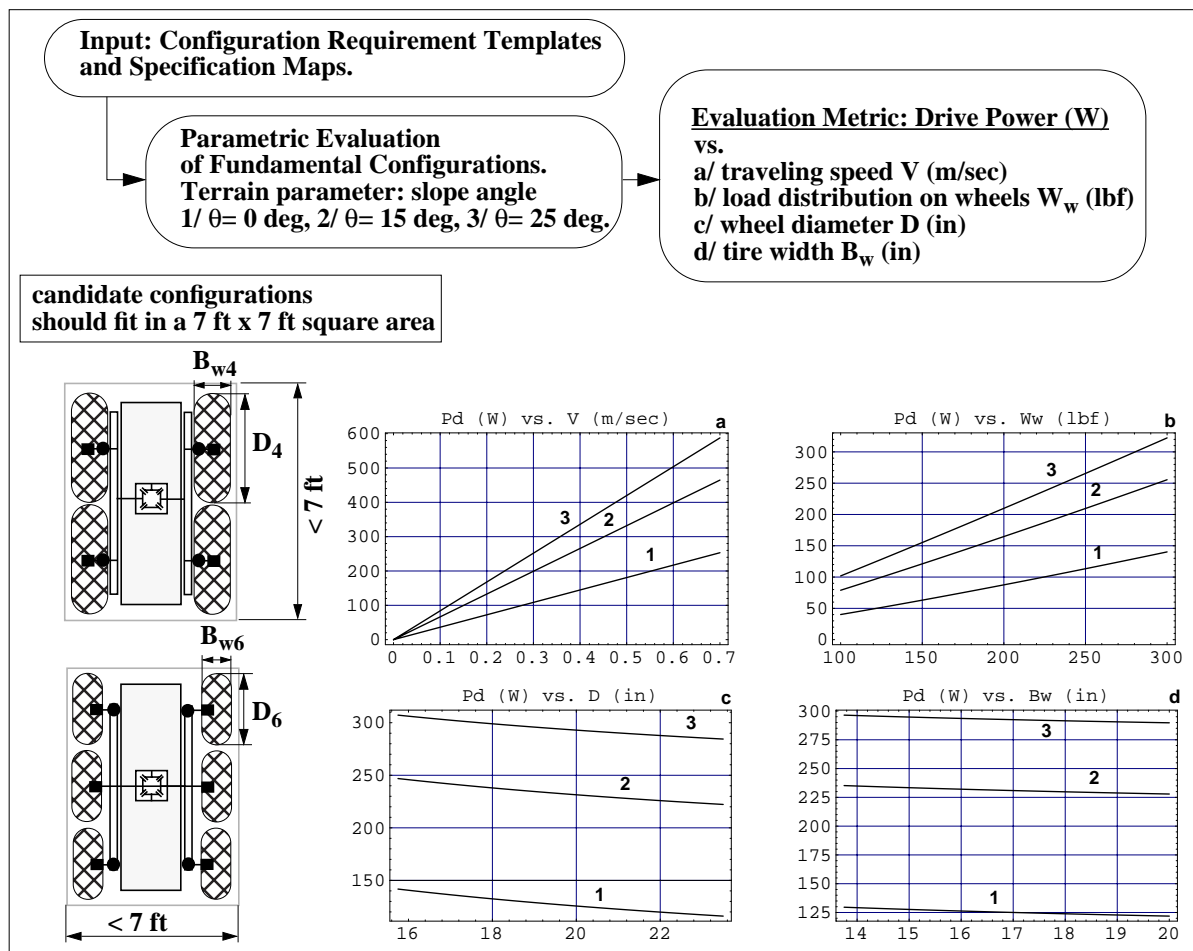
Performance metrics or descriptors are used to evaluate the developed configuration topologies. The mapping process between configuration requirements and locomotion functions could reveal such metrics. Case-based studies and knowledge of previous mobile robot developments could help formulate additional performance metrics of mobility and robotability. The evaluation of configuration topologies is based on how close a topology matches an overall performance index which is formulated from the Configuration Requirement Templates.

*Detailed configuration* transforms a credible topology into a qualified configuration design. Linear programming and quadratic optimization are analysis tools used to refine the configuration design. In addition to satisfying the configuration requirements the configuration design must be responsive to issues of *cost benefit*. Manufacturability, ease of assembly and ease of maintenance are the key contributors to the cost benefit.

Studies of previous robotic developments indicate that it is more realistic to consider cost benefit issues during detailed configuration when there is enough information regarding the geometry of locomotion and fuselage, mass estimates and part counts.

*Case Study: Configuration of Robotic Locomotion for Barren Terrain.*

We have implemented the concepts and practices of fundamental and detailed configuration on the locomotion configuration of a lunar rover terrestrial prototype. This robot’s mission is to traverse 300 km of desert, an environment that is the closest Earth analog to the Moon. We have used the same configuration requirements as the ones presented for the lunar robot. We have only relaxed the mass requirement to compensate for the Earth’s gravitational effects on the structural design of the robot. Using the CRTs and mapping between requirements and locomotion, we have created simple configuration topologies such as those shown in Figure 3-7. We evaluated the fundamental configurations based on parametric analysis and simulation of mobility. The selected configurations are all-wheel driven vehicles with the corner wheels steered. One wheel supports half of the weight of the robot. Figure 3-7 summarizes parametric simulation results in the case that “Power for Driving” is the metric.



**Figure 3-7:** Parametric analysis of four and six-wheel fundamental configurations of the lunar rover.

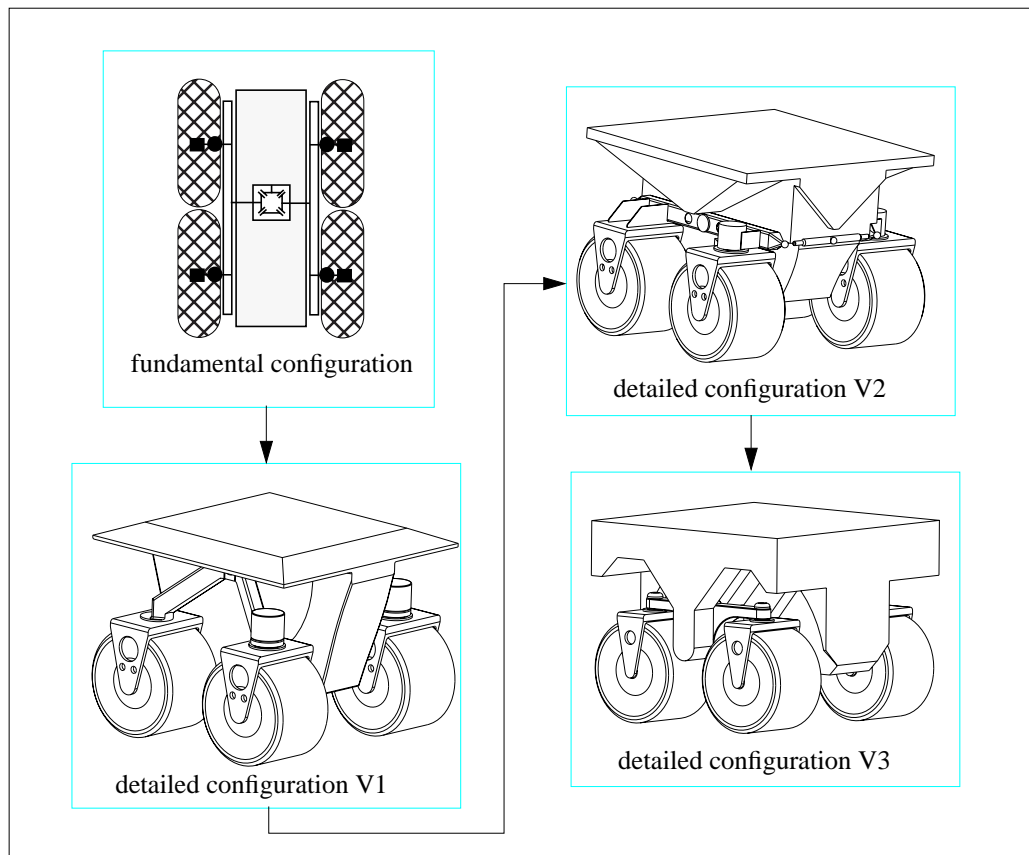
Studies of sinkage, motion resistance, drawbar pull, torque, gradability and other mobility metrics, can be found in the Appendix. We have selected a four-wheel topology with  $(D, B_w)=(30'', 20'')$  and a six-wheel topology with  $(D, B_w)=(20'', 15.75'')$  as the most promising configuration topologies regarding mobility (Table 3-4). A comparison of the two configurations reveals that a four-wheel design is more appropriate than a six wheel design when “traversability of soft soils” is the performance issue and both configurations are subject to the same mission/task performability requirements (Table 3-1). Because of lower total motion resistance and higher drawbar pull, the four-wheel configuration should develop more traction and negotiate steeper slopes than the six-wheel configuration. The six-wheel imposes lower torque requirements due to the significantly smaller wheel diameter. However, the power draw is lower for the four-wheel configuration because of the slower rotational speed required to run the drive actuators. We should note that this study is one of many used to weigh the two configurations. Other studies such as that of “terrain smoothing for reducing sensor vibrations” favor the six-wheel configuration, but detailed analysis is needed to quantify the predicted performance as accurately as possible.

Performance Descriptor	6 wheels D= 20'' B <sub>w</sub> = 15.75''	4 wheels D= 30'' B <sub>w</sub> = 20''	% change from six to four wheels
Wheel load and contact area	275 lbf/wheel, A= 250 in <sup>2</sup>	275 lbf/wheel, A= 250 in <sup>2</sup>	-
1. Sinkage [in]	1.34	1.01	↓ 24.6% (+)
2. Soil thrust [lbf]	175	175	-
3a. Compaction resistance [lbf]	54	38	↓ 29.6% (+)
3b. Bulldozing resistance [lbf]	14	10	↓ 28.6% (+)
3c. Rolling resistance [lbf]	14	14	-
3d. Gravitational component [lbf]	0	0	-
3. (sum of 3s) Total resistance [lbf]	82	62	↓ 24.4% (+)
4. Drawbar pull [lbf]= 2 - 3	93	113	↑ 21.5% (+)
5. Max. negotiable slope [deg]	18.7	22.3	↑ 21.2% (+)
6. Drive torque/wheel [in-lb]	860	930	↑ 8.1% (-)
7. Traveling speed [m/sec]	0.35	0.35	-
9. Drive power/wheel (input) [W]	222	167.5	↓ 24.6% (+)
10. Total drive power [W]	444	335	↓ 24.6% (+)

**Table 3-4:** Evaluation of four and six-wheel configurations based on trafficability of soft soils (dry sand). The (+) in the last column indicates performance improvement if the four-wheel is selected.



Version 1 of the detailed configuration is synthesized from the four-wheel topology whose locomotion subsystems have been dimensioned, analyzed and laid out during fundamental configuration. In order to increase the payload volume of the body fuselage and minimize interferences between the steered wheels and the lower section of the body we have implemented a motion interference analysis to generate a new body geometry. The result is Version 2 of the detail configuration. To satisfy all of the mission/task performability requirements more optimization is needed. In Version 3 steering and suspension components have been modified to function from inside the body fuselage and body geometry has been simplified. These changes result to a minimum number of exposed moving parts and geometry that accommodates thermal design and protects the actuators from the harsh desert environment. The evolution of configurations is summarized below:



**Figure 3-8:** Evolution and optimization of the lunar robot terrestrial prototype locomotion configurations.

---

## Summary and Contributions

In this technical report we introduce a framework for systematic configuration of robotic locomotion. The framework is a sequence of processes which, step-by-step, transforms the robotic ask specification into rationalized configurations of the robot's mobility system. *Systematization* and *analysis* are the two elements that make the proposed framework unique.

Systematization is motivated by the need to improve the state-of-practice which is inefficient, expensive, and in many cases fails to address the issues governing the design of complex robotic archetypes. The proposed framework consists of three phases:

- **Mapping between configuration requirements and robotic locomotion.** Requirements analysis leads this phase. We introduce four classes of requirements relevant to locomotion configuration: mission/task performability, mobility/terrainability, robotability and reliability. The challenge is to extract requirements from the problem statement and redefine them in such a way that can be mapped to one or more of the four classes of configuration requirements. We introduce the concept of Configuration Requirement Templates (CRTs) which allows for an explicit representation of performance objectives and the associated requirements. The configuration requirements are then mapped to the locomotion subsystems. The mapping process could be as simple as acknowledging the dependence between a requirement and a subsystem or it could involve analysis to extract parametric equations that relate configuration requirements and locomotion functions.
- **Fundamental configuration.** Fundamental configuration is the process that synthesizes, analyzes and evaluates locomotion configurations. This research does not propose generic methods for creating alternative configurations. Instead, it demonstrates how parametric analysis can be used to quantify simple configurations and assist the selection process. In the case of the lunar robot terrestrial prototype four and six-wheel configurations are created using common engineering principles. The decision regarding “four-wheels versus six-wheels” is based on studies of mobility, terrainability and robotability. In this sense, we synthesize rather than generate rational configuration topologies.
- **Detail configuration.** This phase is pivotal in that it produces an optimal configuration which is then designed and built. The optimal configuration design contains sufficient information about the form and function of the locomotion subsystems. Operational analysis (torque, power, energy), kinematic and dynamic simulation, and optimization are the analytical tools used to refine locomotion geometry and subsystem layout. The performance specification of the configuration design should satisfy all of the configuration requirements. Detailed configuration should also address the issue of reliability. Reliability is achieved by introducing margins to the geometric and functional configuration of the locomotion subsystems. Margins are necessary to accommodate growth in mass and volume during design and to enhance the intrinsic safeguarding capabilities of the robot, such as recoverability from terrain contingencies.

We view the contributions of this research to robotics as:

- Produces a systematic framework for detailed and rationalized configuration of robotic locomotion.
- Implements analytical methods to configure robotic locomotion.
- Introduces robotability as the ability to accommodate sensing and teleoperation, and to execute autonomous planning in a reliable and efficient manner.
- Demonstrates how mobility, terrainability and robotability requirements affect robotic configuration.
- Demonstrates how terramechanics, the science of terrain/vehicle systems, relates to robotic locomotion.

---

# References

- [Amai93] Amai, W., A., et al., "Robotic All-Terrain Lunar Exploration Rover (RATLER): FY93 Program Status Report", Sandia National Laboratories, SAND94-1706, October 1994.
- [Apostolopoulos91-1] Apostolopoulos, D., "A Model for Generating Function Structures and Solution Concepts in Mechanical Systems Design", "AI in Design" Report, Carnegie Mellon University, 1991.
- [Apostolopoulos91-2] Apostolopoulos, D., and Desa, S., "Concurrent Design of Electromechanical Systems for Performance", M.E. Thesis, Department of Mechanical Engineering, Carnegie Mellon University, 1991.
- [Apostolopoulos95] Apostolopoulos, D., and Whittaker, W. L., "Robotic Locomotion for Lunar Exploration", Proceedings of the 2nd International Lunar Exploration Conference, San Diego, CA, 1995.
- [Bares87] Bares, J., *Responsive Prototyping of Mobile Unmanned Work Systems*, M.E. Thesis in Civil Engineering, Carnegie Mellon University, May 1987.
- [Bares91] Bares, J., *Configuration of Autonomous Walkers for Extreme Terrain*, Ph.D. Dissertation in Civil Engineering, Carnegie Mellon University, 1991.
- [Beitz87] Beitz, W., "General Approach of Systematic Design", Proceedings of the ASME International Conference on Engineering Design, pp. 15-20, New York, NY, 1987.
- [Bekker56] Bekker, M., G., *Theory of Land Locomotion: The Mechanics of Vehicle Mobility*, University of Michigan Press, Ann Arbor, MI, 1956.
- [Bekker60] Bekker, M., G., *Off-The-Road Locomotion*, University of Michigan Press, Ann Arbor, MI, 1960.
- [Bekker64] Bekker, M., G., "Mechanics of Locomotion and Lunar Surface Vehicle Concepts", Transactions of the Society of Automotive Engineers, Vol. 72, pp. 549-569, 1964.
- [Bekker69] Bekker, M., G., *Introduction to Terrain-Vehicle Systems*, University of Michigan Press, Ann Arbor, MI, 1969.
- [Bickler92] Bickler, D., B., "The New Family of JPL Planetary Surface Vehicles", Proceedings of the Conference on Missions, Technologies and Design of Planetary Mobile Vehicles, pp. 301-306, Toulouse, France, September 1992.
- [Boeing92] The Boeing Company, Advanced Civil Space Systems Division, "Piloted Rover Technology Task 9.4 Final Report", NASA Contract NAS8-37857, 1992.

- [Burke92] Burke, J., D., "Past US Studies and Developments for Planetary Rovers", Proceedings of the Conference on Missions, Technologies and Design of Planetary Mobile Vehicles, pp. 45-60, Toulouse, France, September 1992.
- [Carrier92] Carrier, D., W., "Soviet Rover Systems", AIAA Space Programs and Technologies Conference, March 1992.
- [Cross89] Cross, N., *Engineering Design Methods*, John Wiley & Sons Ltd., Chichester, UK, 1989.
- [Heiken91] Heiken, G., et al, *Lunar Sourcebook: A User's Guide to the Moon*, Cambridge University Press, Cambridge, UK, 1991.
- [Hirose91] Hirose, S., "Three Basic Types of Locomotion in Mobile Robots", Proceedings of IEEE International Conference on Robotics and Automation, 1991.
- [Hoffman92] Hoffman, S., J., and Weaver, D. B., "Results and Proceedings of the Lunar Rover/Mobility Systems Workshop", EXPO-T2-920003-EXPO, NASA, 1992.
- [Hubka88] Hubka, V., Eder, W., E., *Theory of Technical Systems*, Springer-Verlag, Berlin, Germany, 1988.
- [Jones70] Jones, J., C., *Design Methods*, Council of Industrial Design, John Wiley & Sons Ltd., London, UK, 1970.
- [JPL87] Jet Propulsion Laboratory, Proceedings of Mars Rover Technology Workshop, Volume #3: Mobility, April 1987.
- [Kannapan87-1] Kannapan, S., and Marshek, K., M., "Design Methodologies: A New Perspective on Approaches and Tasks", Mechanical Systems and Design, Technical Report 201, University of Texas, Austin, TX, August 1987.
- [Kannapan87-2] Kannapan, S., and Marshek, K., M., "Design Synthetic Reasoning: A Program for Search", Mechanical Systems and Design, Technical Report 202, University of Texas, Austin, TX, August 1987.
- [Keller71] Keller, R., E., *Statics and Dynamics of Components and Systems*, John Wiley & Sons, Inc., New York, NY, 1971.
- [Kelly95] Kelly, A., *An Intelligent, Predictive Control Approach to the High Speed Cross Country Autonomous Navigation Problem*, Ph.D. Dissertation in Robotics, Carnegie Mellon University, 1995.
- [Kemp90] Kemp, H., R., "Climbing Ability of Four-Wheel-Drive Vehicles", Journal of Terramechanics, Vol. 27, No. 1, pp. 7-23, 1990.
- [Kemp91] Kemp, H., R., "Relative Contributions of Different Wheels of Four-Wheel-Drive Vehicles", Journal of Terramechanics, Volume 28, No. 4, pp. 393-402, 1991.
- [Kemurdjian92] Kemurdjian, A., L., et al., "Soviet Developments of Planetary Rovers in Period of 1964-1990", Proceedings of the Conference on Missions, Technologies and Design of Planetary Mobile Vehicles, pp. 25-43, Toulouse, France, September 1992.

- [Kemurdjian95] Kemurdjian, A., L., and Potemkin, E., K., “Mobility of Planetary Vehicles: Problems and Reality”, Proceedings of the American Nuclear Society Conference on), pp. 433-442, 1995.
- [Klarer93] Klarer, P., R., and Purvis, J., W., “A Highly Agile Mobility Chassis Design for a Robotic All-Terrain Lunar Exploration Rover”, ASCE proceedings, 1992.
- [Koller76] Koller., R., *Konstruktionsmethode fur den Maschinen-, Gerate- und Apparatebau*, Springer Verlag, Berlin, 1976.
- [Larminie88] Larminie, J. C., “Standards for Mobility Requirements of Military Vehicles”, Journal of Terramechanics, Vol. 25, No. 3, pp. 171-189, 1988.
- [Lindemann92] Lindemann, R., A., and Eisen, H., J., “Mobility Analysis, Simulation and Scale Model Testing for the Design of Wheeled Planetary Rovers”, Proceedings of the Conference on Missions, Technologies and Design of Planetary Mobile Vehicles, pp. 531-536, Toulouse, France, September 1992.
- [Littmann92] Littmann, F., Villedieu, E., and Idasiak, J., M., “Mechanical Design of a Planetary Rover”, Proceedings of the Conference on Missions, Technologies and Design of Planetary Mobile Vehicles, pp. 345-359, Toulouse, France, September 1992.
- [MMSSC88] Martin Marietta Space Systems Company, “Mars Rover/Sample Return (MRSR) Rover Mobility and Surface Rendezvous Studies”, JPL Contract 958073, October 1988.
- [Pahl84] Pahl, G., and Beitz, W., *Engineering Design*, The Design Council, Springer-Verlag, London, UK, 1984.
- [Price90] Price, S., et al., “Wheeled Planetary Rover Testbed”, SPIE The International Society of Optical Engineering, Vol. 1388, pp. 550-559, 1990.
- [Roth87] Roth, K., “Design Models and Design Catalogs”, Proceedings of the International Conference in Engineering Design, pp.60-67, Boston, MA, 1987.
- [Spiessbach87] Spiessbach, A., et al., “Issues and Options for a Mars Rover”, SPIE The International Society of Optical Engineering, Vol. 852, pp. 163-171, 1987.
- [Todd85] Todd, D., *Walking Machines: An Introduction to Legged Robots*, Chapman and Hall, New York, NY, 1985.
- [Turnage89] Turnage, G. W., and Banks, D., C., “Lunar Surface Mobility Studies Past and the Future”, Miscellaneous Paper G1-89-26, Geotechnical Laboratory, US Army Engineer Waterways Experiment Station, 1989.
- [VDI87] Verein Deutscher Ingenieure, “Systematic Approach to the Design of Technical Systems and Products”, VDI Guidelines 2221, August 1987.
- [Waldron85-1] Waldron, K., J., “The Mechanics of Mobile Robots”, Proceedings of the IEEE International Conference on Advanced Robotics, pp. 533-544, 1985.
- [Waldron85-2] Waldron, K., J., “Mobility and Controllability Characteristics of Mobile Robotic Platforms”,?. pp. 237-243, 1985.

- [Wallace93] Wallace, B., and Rao, N., “Engineering Elements for Transportation on the Lunar Surface”, *Applied Mechanics Review*, Vol. 46, No. 6, June 1993.
- [Whittaker95-1] Whittaker, W., L., et al., “Design of a Day/Night Lunar Rover”, Robotics Institute Technical Report CMU-RI-TR-95-24, Carnegie Mellon University, Pittsburgh, PA, 1995.
- [Whittaker95-2] Whittaker, W., L., Apostolopoulos, D., and Katragadda, L., “Lunar Rover Initiative”, *Proceedings of the International Rover Workshop, International Conference on Robots and Systems IROS '95*, Pittsburgh, pA, 1995.
- [Wong68] Wong, R., E., “Surface Mobility Systems for Lunar Exploration”, *Transactions of the Society of Automotive Engineers*, Vol.), pp. 1196-1212, 1968.
- [Wong93] Wong, J., Y., *Theory of Ground Vehicles*, John Wiley & Sons, Inc., New York, NY, 1993.

# Appendix: Mobility Analysis

## List of Symbols

a	linear acceleration	ft/sec <sup>2</sup>
b'	corrected width of loading area	in
b <sub>w</sub> or B <sub>w</sub>	tire width, wheel/soil contact width	in
c	cohesion of soil	lbf/in <sup>2</sup> (psi)
d <sub>w</sub> or D	wheel diameter	in
f <sub>r</sub>	coefficient of rolling friction	-
i	reduction ratio	-
j	soil deformation	in
k <sub>c</sub>	cohesive modulus of soil deformation	lbf/in <sup>n+1</sup>
k <sub>φ</sub>	frictional modulus of soil deformation	lbf/in <sup>n+2</sup>
l <sub>w</sub>	length of the loading area	in
l'	corrected length of loading area	in
m	vehicle mass	lbm or lbf.sec <sup>2</sup> /ft
n	exponent of sinkage	-
p	ground pressure	lbf/in <sup>2</sup> (psi)
r	wheel radius	in
z	wheel sinkage	in
A	ground contact area	in <sup>2</sup>
B <sub>v</sub>	total vehicle width	in or ft
H	soil thrust	lbf
DP	drawbar pull	lbf
J	moment of inertia	lbf.ft.sec <sup>2</sup>
K	slip coefficient	in
L <sub>v</sub>	total vehicle length	in or ft
R <sub>x</sub>	motion resistance due to x	lbf
V	traveling speed	m/sec
W <sub>w</sub>	wheel loading	lbf
τ	shear stress of soil	lbf/in. <sup>2</sup> (psi)
θ	slope angle	deg
φ	angle of internal friction of soil	deg



In this section we present parametric analysis and simulation studies of mobility. Using statics and terramechanics we have developed relationships between locomotion configuration parameters and the performance metrics of:

- Sinkage ( $z$ )
- Motion resistance ( $R_{all}$ )
- Drawbar pull (DP)
- Drive Torque ( $T_d$ ) and Drive Power ( $P_d$ )
- Gradability, which is the maximum slope ( $\theta_{max}$ ) that the robot can negotiate.

Each performance metric is described as a mathematical function of wheel diameter, tire width, wheel loading, traveling speed, total vehicle length, etc. This study focuses on the mobility of the terrestrial prototype of the lunar robot operating in dry sand. We will present terrainability and robotability analyses in a future report.

Property	Lunar Soil	Desert Dry Sand
Exponent of sinkage (n)	1.0	1.1
Cohesive modulus of soil deformation ( $k_c$ )	0.20 lb/in <sup>n+1</sup>	0.10 lb/in <sup>n+1</sup>
Frictional modulus of soil deformation ( $k_\phi$ )	3.0 lb/in <sup>n+2</sup>	3.9 lb/in <sup>n+2</sup>
Cohesion of soil (c)	0.025 psi	0.151 psi
Coefficient of slip (K)	0.7 in	0.4 in (firm), 1.0 in (loose)
Angle of internal friction ( $\phi$ )	40 deg	28 - 38 deg

**Table A-1:** Geophysical properties of the lunar regolith and dry sand.

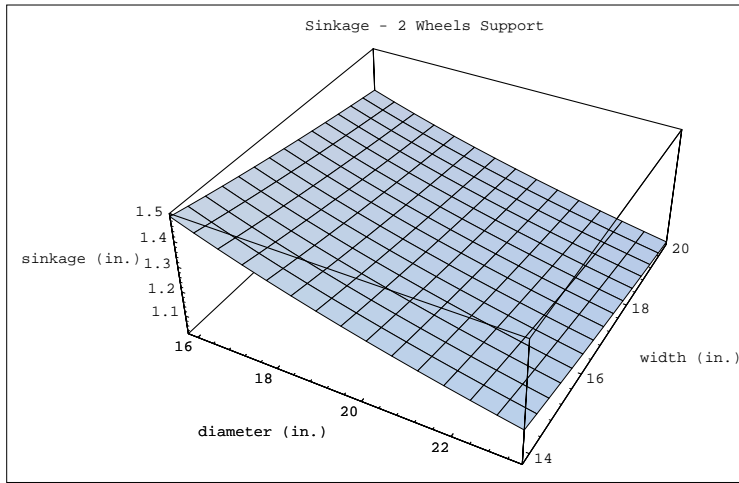
## 1. Sinkage

- Flat rigid loading area, high deflection elastic tire:

$$z_{ew} = \left( \frac{p}{\left( \frac{k_c}{B_w} + k_\phi \right)} \right)^{\frac{1}{n}} \quad [\text{eq.A1}]$$

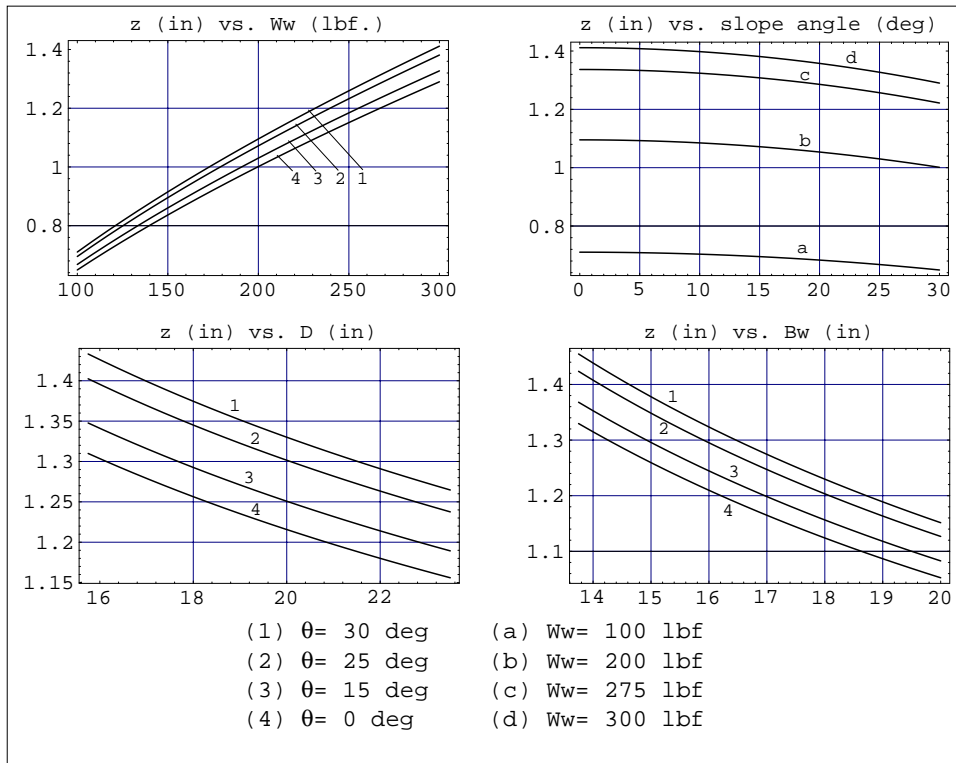
- Rigid wheel or low deflection tire:

$$z_{rw} = \left( \frac{3W_w}{(3-n)(k_c + bB_w k_\phi) \sqrt{D}} \right)^{\frac{2}{(2n+1)}} \quad [\text{eq.A2}]$$



**Figure A-1:** Wheel sinkage  $z$  (in) of a rigid wheel as a function of wheel diameter  $D$  (in) and tire width  $B_w$  (in) (wheel loading  $W_w=275$  lbf).

Parametric simulations of wheel sinkage:



**Figure A-2:** Wheel sinkage  $z$  (in) in dry sand as a function of wheel loading  $W_w$  (lbf) and the slope angle  $\theta$  (deg) in the upper row (in both cases  $D=20"$ ,  $B_w=15.75"$ ), and wheel diameter  $D$  (in) and tire width  $B_w$  (in) in the lower row (in both cases wheel load  $W_w=275$  lbf).

## 2. Motion Resistance

Drawbar pull is the difference between soil thrust and motion resistance. Locomotion is sustained if the soil thrust exceeds motion resistance and the robot's propulsion system can provide enough torque and power to react to the moments of the resistive forces:

$$DP = H - R \quad [\text{eq.A3}]$$

Soil thrust (H) can be computed by integrating the shear deformation capability of the soil ( $\tau$ ) over the contact area of the wheel:

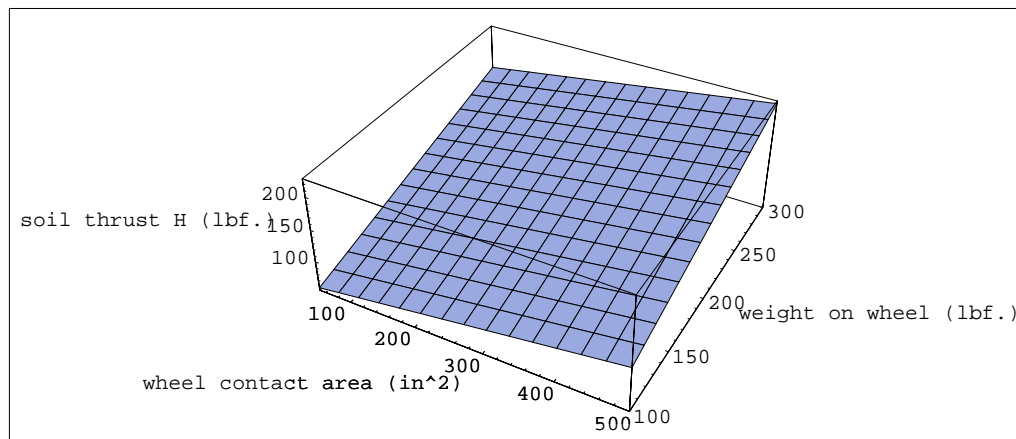
$$\tau = (c + p \tan \phi) \left( 1 - e^{-\frac{J}{K}} \right) \quad [\text{eq.A4}]$$

$$H = \iint (c + p \tan \phi) \left( 1 - e^{-\frac{J}{K}} \right) dx dy \quad [\text{eq.A5}]$$

$$H = (cA + W_w \cos(\theta) \tan \phi) \left( 1 - e^{-\frac{J}{K}} \right)$$

with the loading area (A) for tire-type wheels determined as follows:

$$A = \left( \frac{\pi}{4} \right) b' l' \quad [\text{eq.A6}]$$



**Figure A-3:** Soil thrust H (lbf) as a function of wheel/soil contact area A (in<sup>2</sup>) and wheel loading  $W_w$  (lbf).

Motion resistance ( $R_{all}$ ) consists of:

- Soil compaction resistance ( $R_c$ )
- Soil bulldozing resistance ( $R_b$ )
- Rolling resistance ( $R_r$ ) due to scrubbing in the contact patch, tire deflection and slip, etc.

- Resistance due to the gravitational component parallel to the slope ( $R_g$ )
- Steering resistance ( $R_s$ )
- Obstacle climbing resistance ( $R_o$ )
- Acceleration resistance ( $R_a$ ).

Resistance due to steering and obstacle climbing are metrics of terrainability. Resistance due to acceleration is negligible for a slow moving robot. The total resistance is the sum of the various components:

$$R_{all} = R_c + R_b + R_r + R_g + R_s + R_o + R_a \quad [\text{eq.A7}]$$

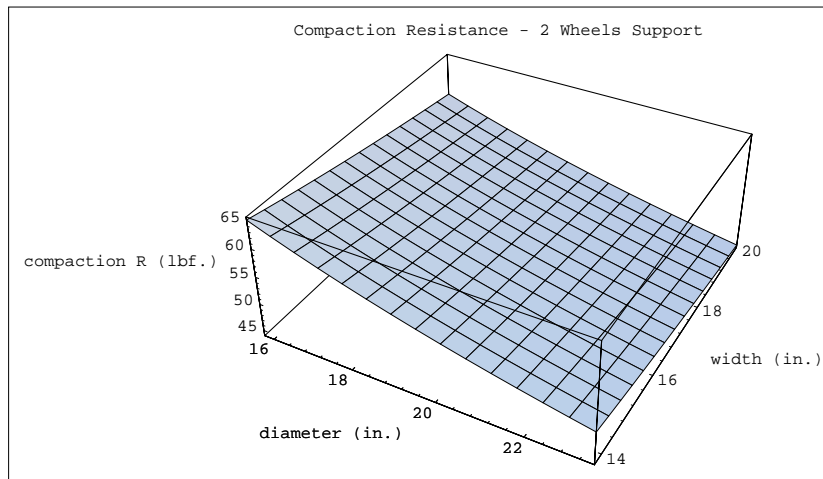
- **Compaction Resistance**

- Compaction resistance of a high-deflection wheel:

$$R_{cew} = \frac{\left( \frac{W_w \cos(\theta)}{l_w} \right)^{\frac{(n+1)}{n}}}{\left( (n+1)(k_c + B_w k_\phi)^{\frac{1}{n}} \right)} \quad [\text{eq.A8}]$$

- Compaction resistance of a rigid wheel:

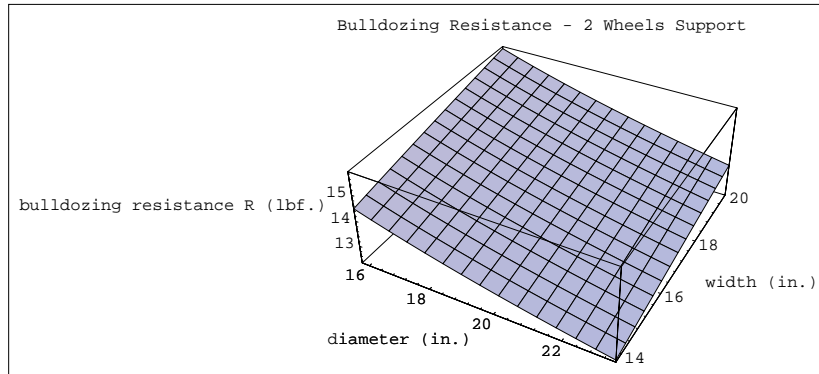
$$R_{crw} = \frac{\left( \frac{3W_w \cos(\theta)}{\sqrt{D}} \right)^{\frac{(2n+2)}{(2n+1)}}}{\left( (3-n)^{\frac{(2n+2)}{(2n+1)}} (n+1)(k_c + B_w k_\phi)^{\frac{1}{(2n+1)}} \right)} \quad [\text{eq.A9}]$$



**Figure A-4:** Compaction resistance  $R_c$  of a rigid wheel as a function of wheel diameter  $D$  (in) and tire width  $B_w$  (in) (wheel loading  $W_w = 275$  lb).

- **Bulldozing resistance**

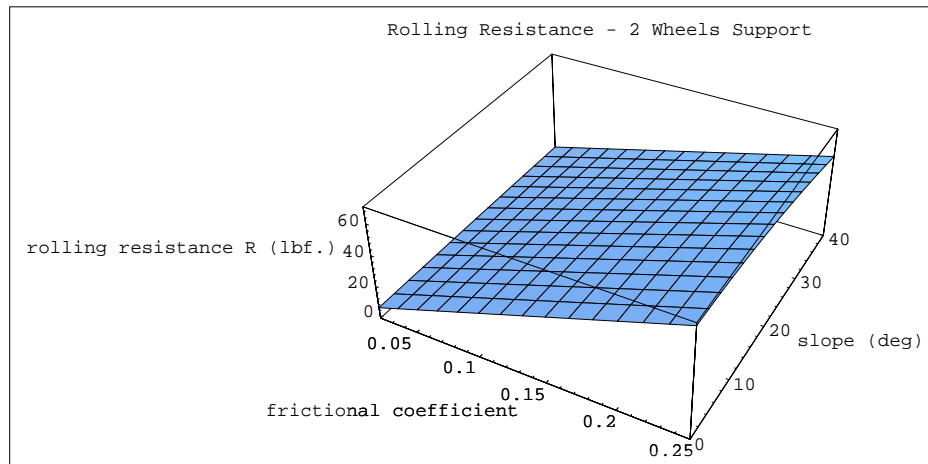
$$R_b = 0.5\alpha b_w z^2 \left( \tan\left(45^\circ + \frac{\phi}{2}\right) \right)^2 + 2cB_w z \tan\left(45^\circ + \frac{\phi}{2}\right) \quad [\text{eq.A10}]$$



**Figure A-5:** Bulldozing resistance  $R_b$  (lb) of a rigid wheel as a function of wheel diameter  $D$  (in) and tire width  $B_w$  (in) (wheel loading  $W_w=275$  lb).

- **Rolling resistance**

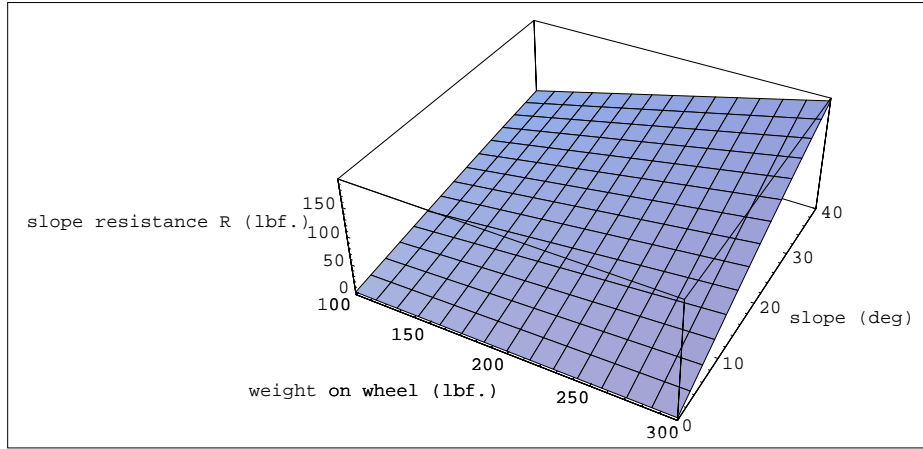
$$R_r = f_r W_w \cos(\theta) \quad [\text{eq.A11}]$$



**Figure A-6:** Rolling resistance as a function of an empirical coefficient of friction  $f_r$  and the slope angle  $\theta$  (deg) (wheel loading  $W_w=275$  lb).

- **Resistance due to gravitational component parallel to a slope**

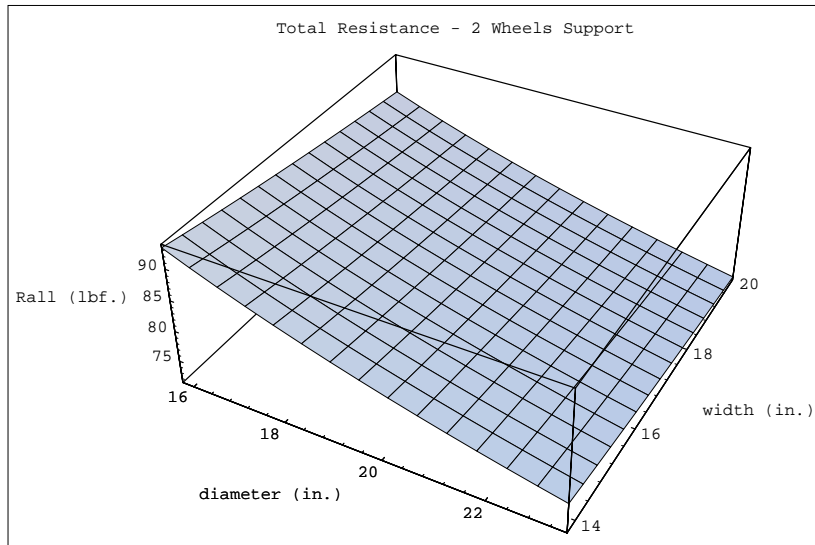
$$R_g = W_w \sin(\theta) \quad [\text{eq.A12}]$$



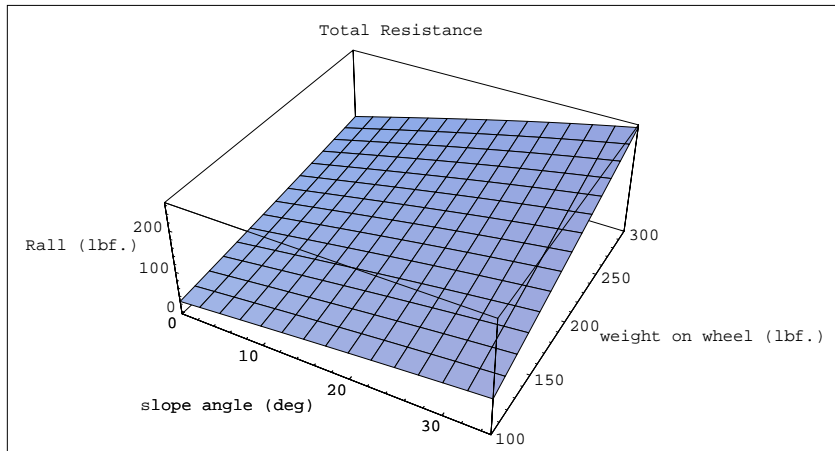
**Figure A-7:** Resistance due to the gravitational component as a function of wheel loading  $W_w$  (lbf) and the slope angle  $\theta$  (deg).

- **Total motion resistance**

$$R_{all} = R_c + R_b + R_r + R_g + R_s + R_o + R_a \quad [\text{eq.A13}]$$

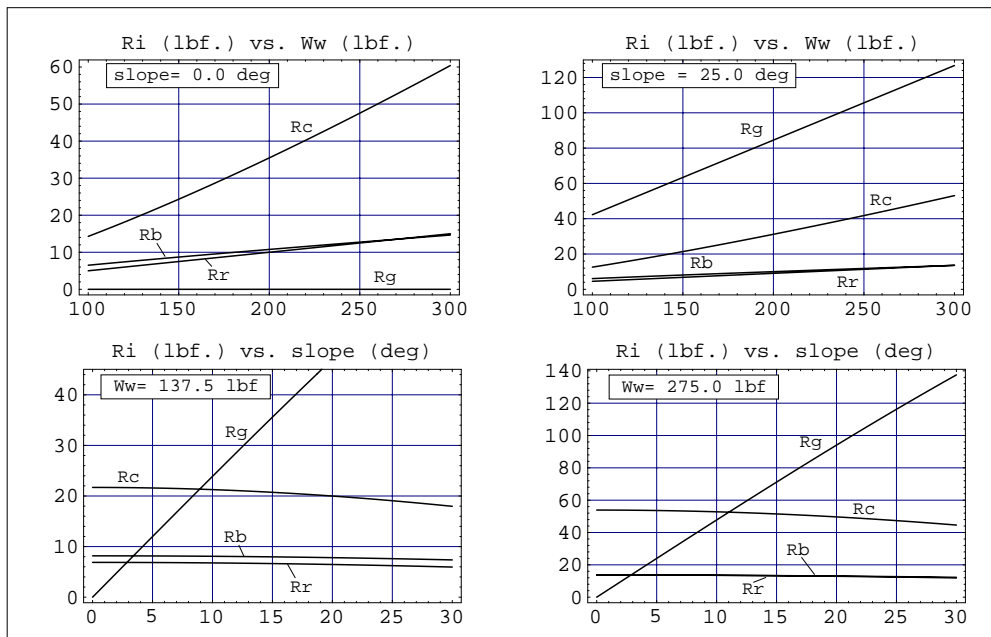


**Figure A-8:** Total motion resistance  $R_{all}$  (lbf) of a rigid wheel as a function of wheel diameter  $D$  (in) and tire width  $B_w$  (in) ( $\theta = 0$  deg,  $f_r = 0.05$ ,  $W_w = 275$  lbf).



**Figure A-9:** Total resistance  $R_{all}$  (lbf) as a function of slope angle  $\theta$  (deg) and wheel loading  $W_w$  (lbf) ( $D= 20"$ ,  $B_w= 15.75'$ ,  $f_r= 0.05$ ).

Parametric simulations of motion resistance components:

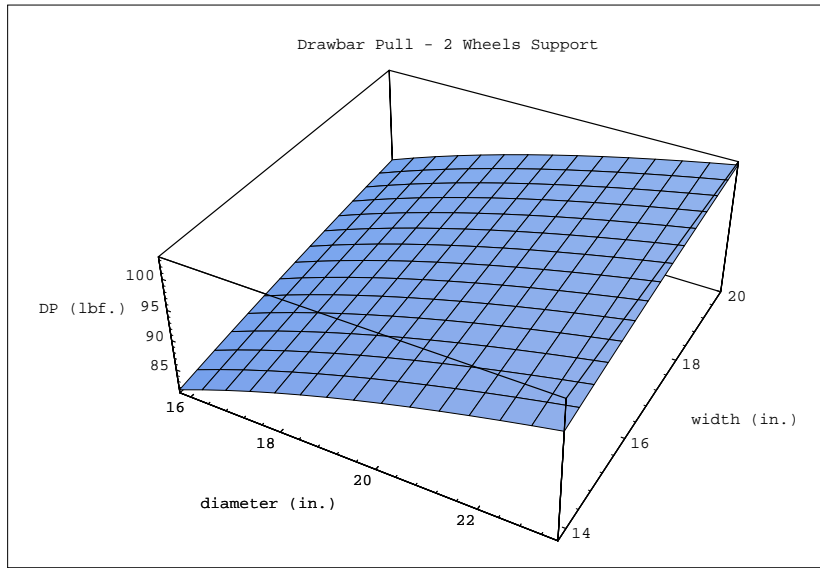


**Figure A-10:** Compaction  $R_c$  (lbf) / Bulldozing  $R_b$  (lbf) / Rolling  $R_r$  (lbf) / Gravitational  $R_g$  (lbf) resistance as a function of wheel loading  $W_w$  (lbf) in the upper row ( $\theta= 0$  deg and  $\theta= 25$  deg) and slope angle  $\theta$  (deg) in the lower row ( $W_w= 137.5$  lbf and  $W_w= 275$  lbf). In all cases:  $D= 20"$ ,  $B_w= 15.75'$ ,  $f_r= 0.05$ .

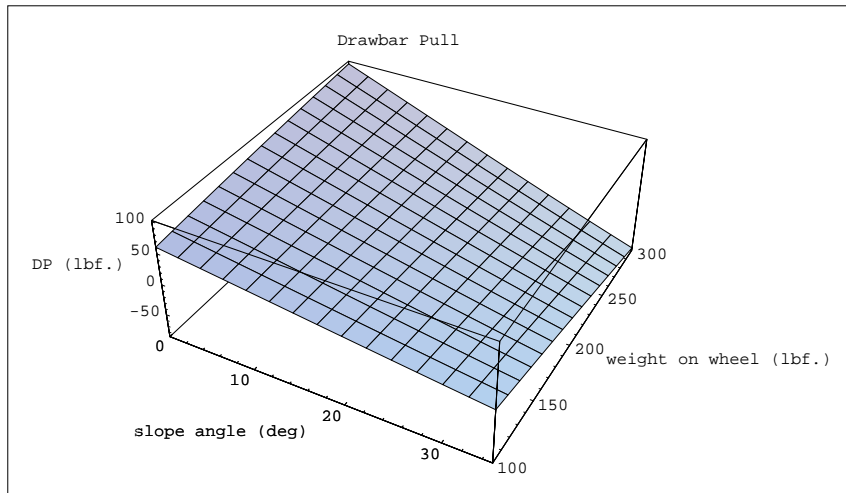
### 3. Drawbar Pull

$$DP = H - R_{all}$$

[eq.A14]



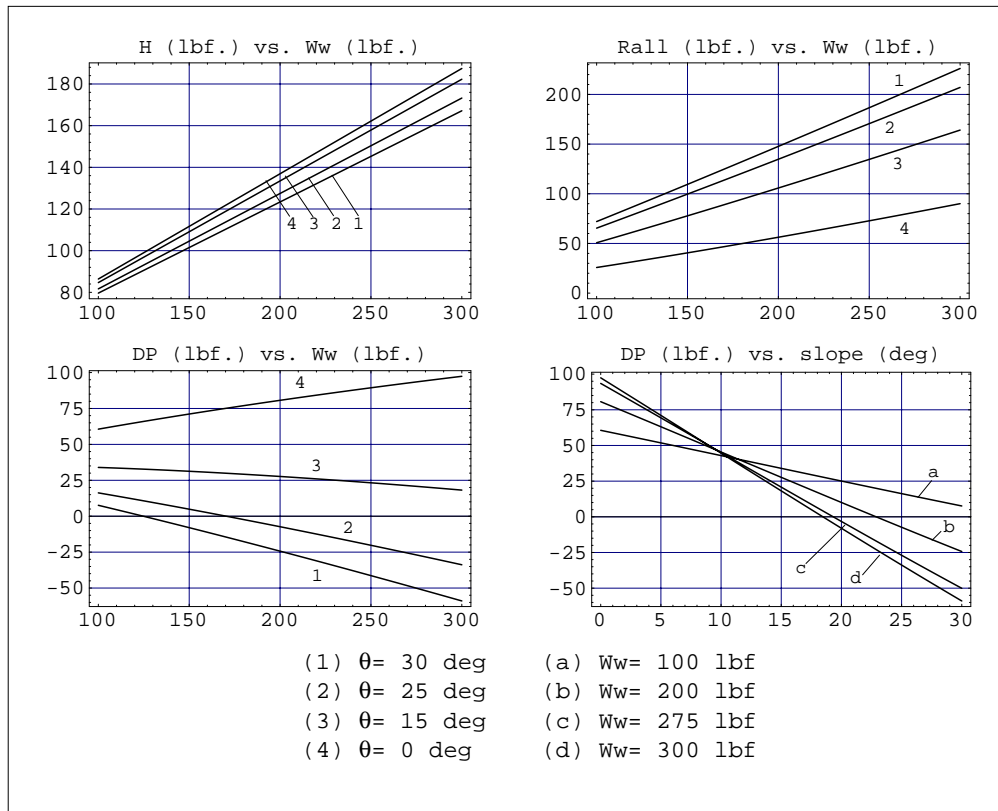
**Figure A-11:** Drawbar pull DP (lbf) developed by a rigid wheel as a function of wheel diameter D (in) and tire width  $B_w$  (in) ( $\theta=0$  deg,  $f_r=0.05$ ,  $A=250$  in<sup>2</sup>,  $W_w=275$  lbf).



**Figure A-12:** Drawbar pull DP (lbf) as a function of the slope angle  $\theta$  (deg) and wheel loading  $W_w$  (lbf) ( $D=20$ ",  $B_w=15.75$ ",  $f_r=0.05$ ).



Parametric simulations of soil thrust, total motion resistance, and drawbar pull:



**Figure A-13:** Soil thrust  $H$  (lbf) and total motion resistance  $R_{all}$  (lbf) as functions of wheel loading  $W_w$  (lbf) in the upper row and drawbar pull  $DP$  (lbf) as a function of wheel loading  $W_w$  (lbf) and the slope angle  $\theta$  (deg) in the lower row. In all cases:  $D = 20''$ ,  $B_w = 15.75''$ ,  $f_r = 0.05$ .

#### 4. Drive Torque and Power

- Torque for driving on flat terrain:

$$T_{drw} = (R_c + R_b + R_r) \left( \frac{d_w}{2} - \delta \right) \quad [\text{eq.A15}]$$

( $\delta = 0.0$  for a rigid wheel)

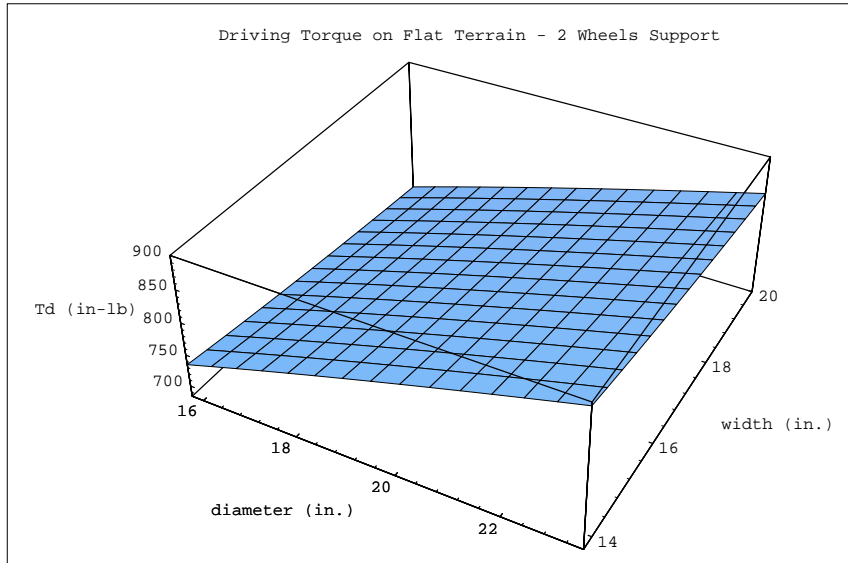


Figure A-14: Drive torque  $T_d$  (in-lb) as a function of wheel diameter  $D$  (in) and tire width  $B_w$  (in) ( $\theta = 0$  deg,  $f_r = 0.05$ ,  $A = 250 \text{ in}^2$ ,  $W_w = 275 \text{ lbf}$ ).

- Torque for driving on sloped terrain:

$$T_{drws} = (R_c + R_b + R_r + R_g) \left( \frac{d_w}{2} - \delta \right) \quad [\text{eq.A16}]$$

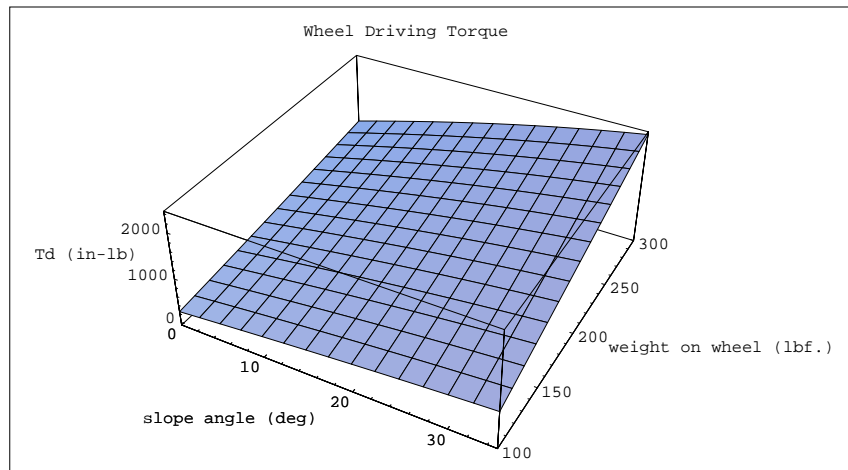
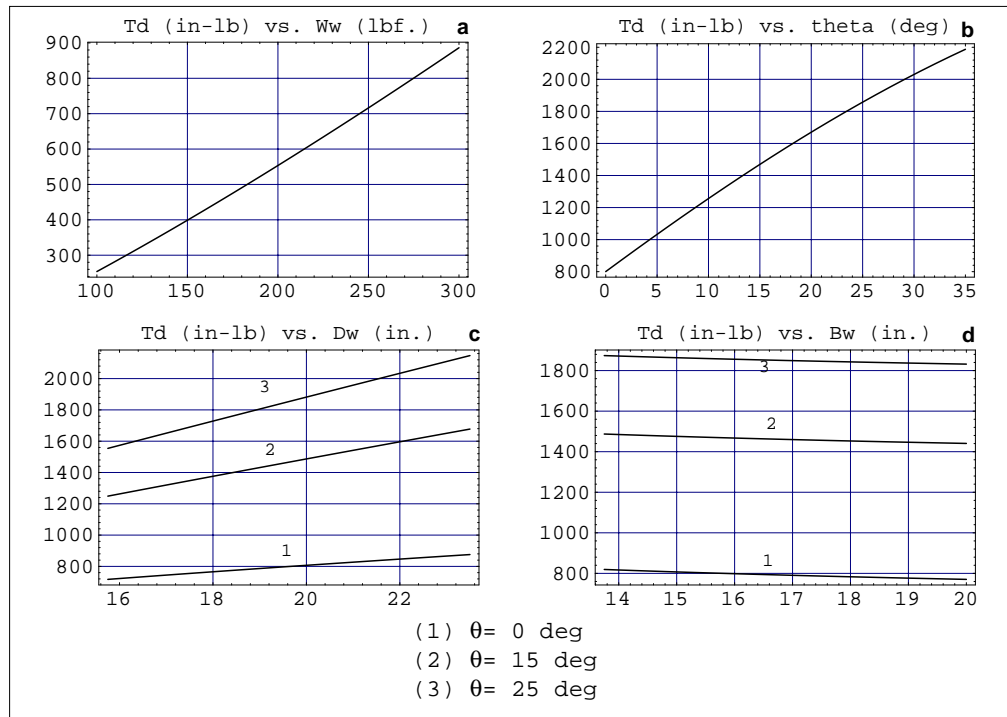


Figure A-15: Drive torque  $T_d$  (in-lb) as a function of the slope angle  $\theta$  (deg) and wheel loading  $W_w$  (lbf) ( $D = 20$ ",  $B_w = 15.75$ ",  $f_r = 0.05$ ).

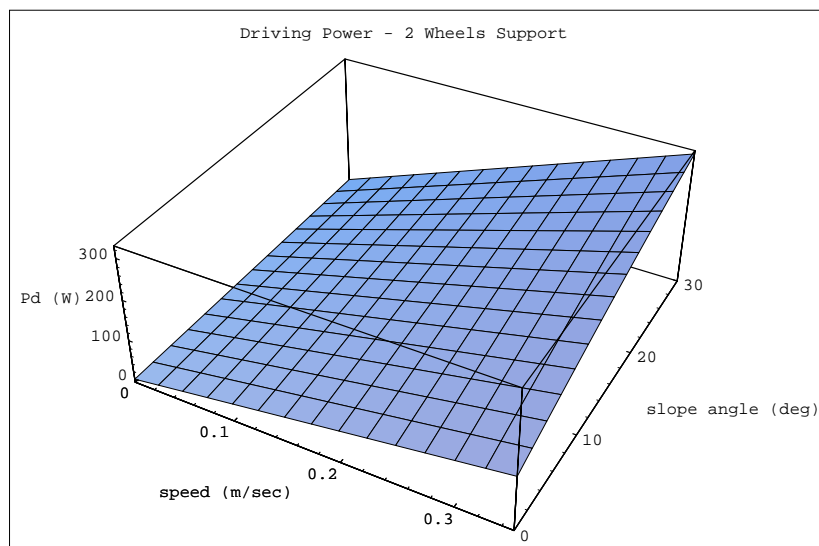
Parametric simulations of drive torque:



**Figure A-16:** Drive torque  $T_d$  (in-lb) as a function of: (a) wheel loading  $W_w$  (lbf) ( $\theta = 0$  deg,  $D = 20$ ",  $B_w = 15.75$ ",  $f_r = 0.05$ ), (b) the slope angle  $q$  (deg) ( $D = 20$ " (50 cm),  $B_w = 15.75$ ",  $f_r = 0.05$ ,  $W_w = 275$  lbf), (c) wheel diameter  $D$  (in), and (d) tire width  $B_w$  (in).

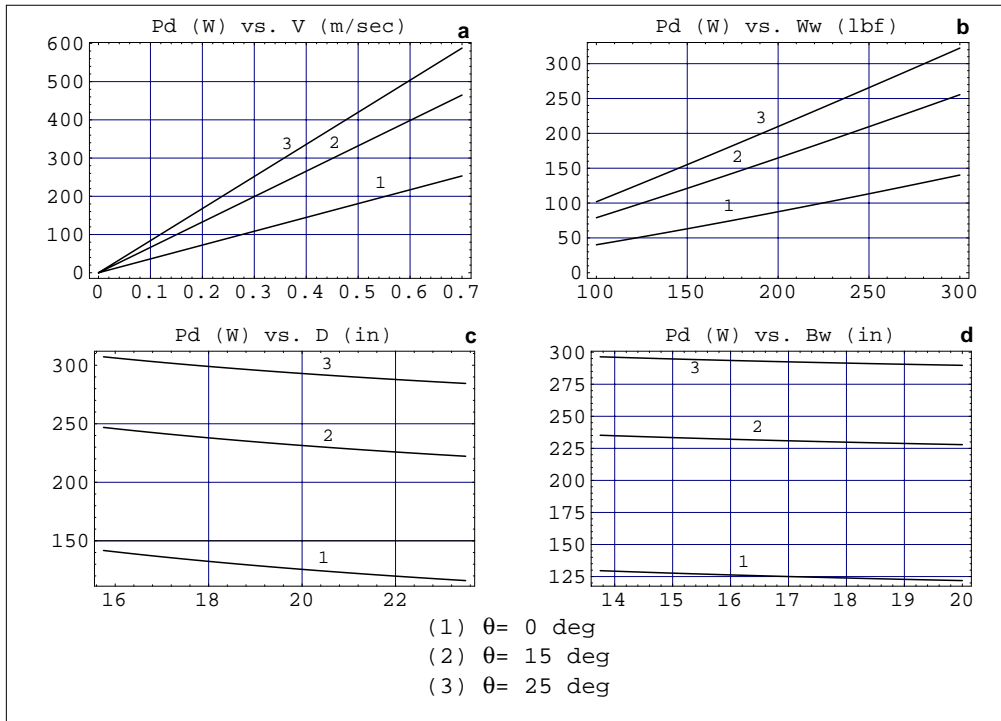
• **Drive Power:**

$$P_{drw} = T_{drw} \left( \frac{2V}{d_w} \right) \quad [\text{eq.A17}]$$

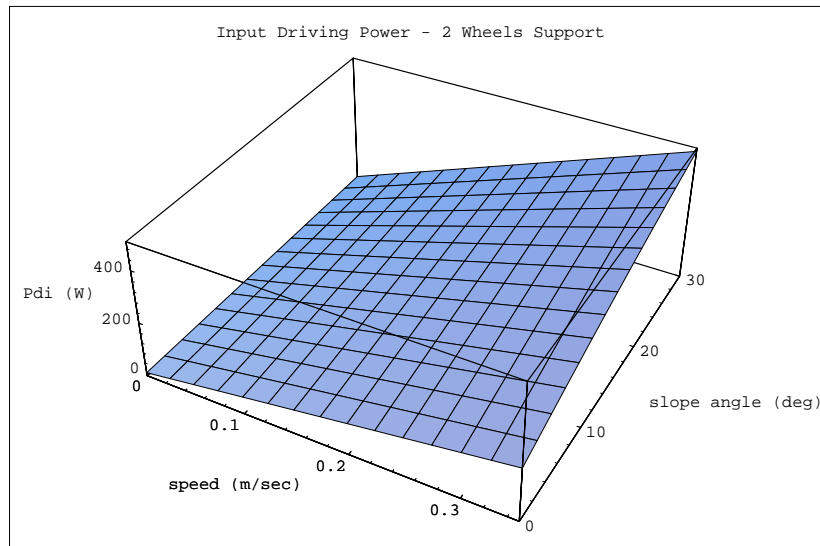


**Figure A-17:** Drive power  $P_d$  (W) as a function of traveling speed  $V$  (m/sec) and the slope angle  $\theta$  (deg) ( $D = 20$ ",  $B_w = 15.75$ ",  $W_w = 275$  lbf,  $f_r = 0.05$ ).

Parametric simulations of drive power:



**Figure A-18:** Drive power  $P_d$  (W) as a function of: (a) traveling speed  $V$  (m/sec) ( $D = 20$ ",  $B_w = 15.75$ ",  $f_r = 0.05$ ,  $W_w = 275$  lbf), (b) wheel loading  $W_w$  (lbf) ( $D = 20$ ",  $B_w = 15.75$ ",  $f_r = 0.05$ ), (c) wheel diameter  $D$  (in), and (d) tire width  $B_w$  (in).



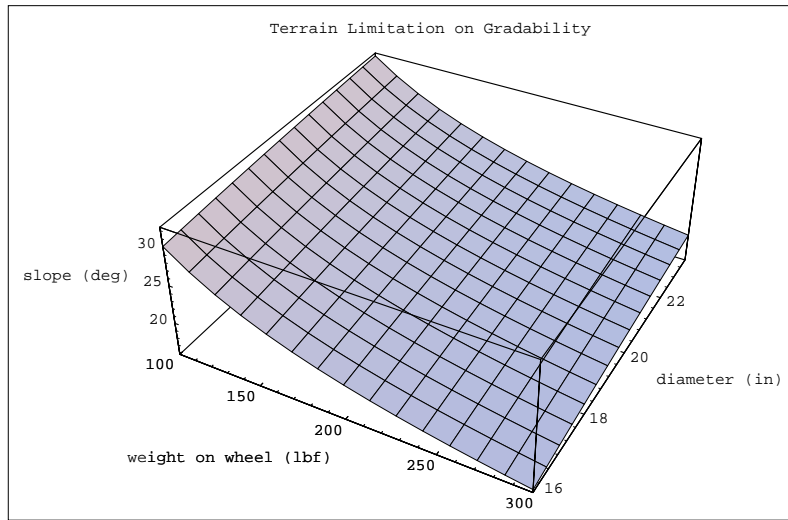
**Figure A-19:** Input\* drive power  $P_{di}$  (W) as a function of traveling speed  $V$  (m/sec) and the slope angle  $\theta$  (deg) ( $D = 20$ ",  $B_w = 15.75$ ",  $W_w = 275$  lbf.,  $f_r = 0.05$ , drivetrain efficiency: 0.85, motor efficiency: 0.80, drive electronics efficiency: 0.90), (\*) power delivered by the motor.

### 5. Slope Negotiation

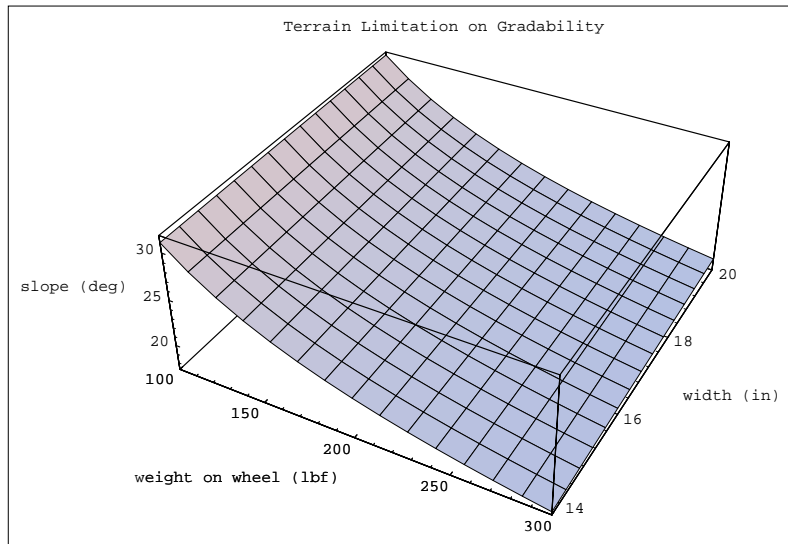
The capability of a wheeled robot to climb over sloped terrain is limited by the shear strength of the soil and the static stability margins of the robot. The ratio of drawbar pull to wheel loading of a robot climbing a slope at a steady-state fashion and at a 20% slip, is approximately equal to its gradability. We assume that the vehicle has enough prime power to climb slopes steeper than those dictated by the two gradability criteria.

- **Gradability based on the drawbar pull ratio:**

$$\theta_{max} = \text{atan}\left(\frac{DP}{W_w}\right) \tag{eq.A18}$$

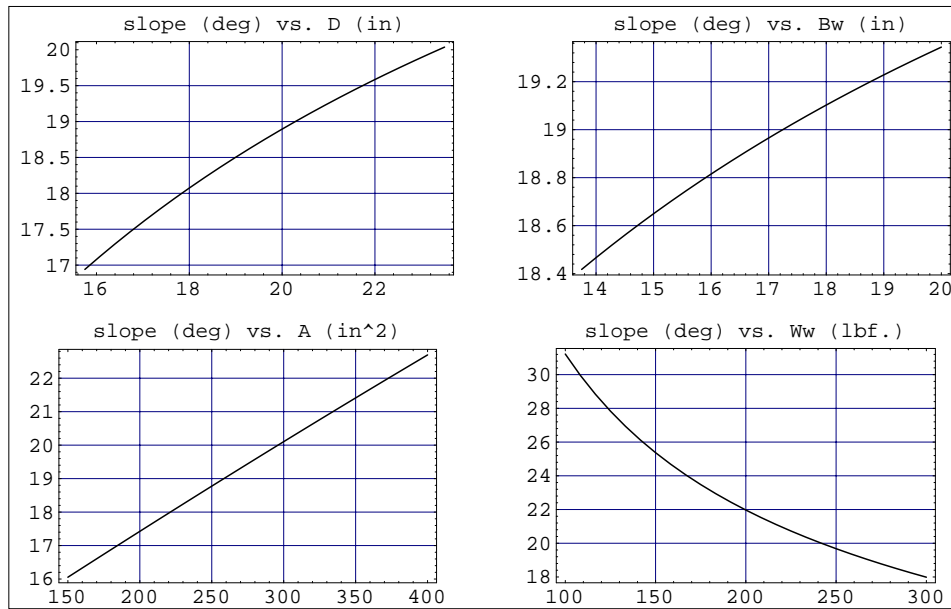


**Figure A-20:** Gradability (max. slope in deg) as a function of wheel loading  $W_w$  (lbF) and wheel diameter  $D$  (in) ( $B_w=15.75"$ ,  $f_r=0.05$ ).



**Figure A-21:** Gradability (max. slope in deg) as a function of wheel loading  $W_w$  (lbF) and tire width  $B_w$  (in) ( $D=20"$ ,  $f_r=0.05$ ).

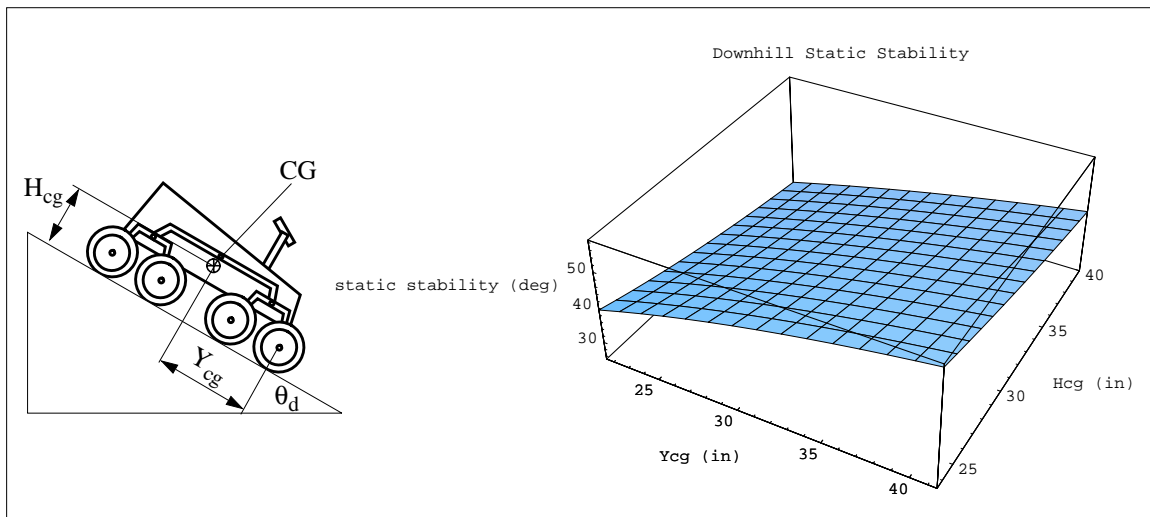
Parametric simulations of gradability:



**Figure A-22:** Gradability (max. slope in deg) as a function of wheel diameter  $D$  (in), tire width  $B_w$  (in), contact area  $A$  (in<sup>2</sup>), and wheel loading  $W_w$  (lbf). In case that a parameter is fixed the following values are used:  $D= 20"$ ,  $B_w= 15.75"$ ,  $A= 250$  in<sup>2</sup>,  $W_w= 275$  lbf.

- Downhill gradability based on static stability:**

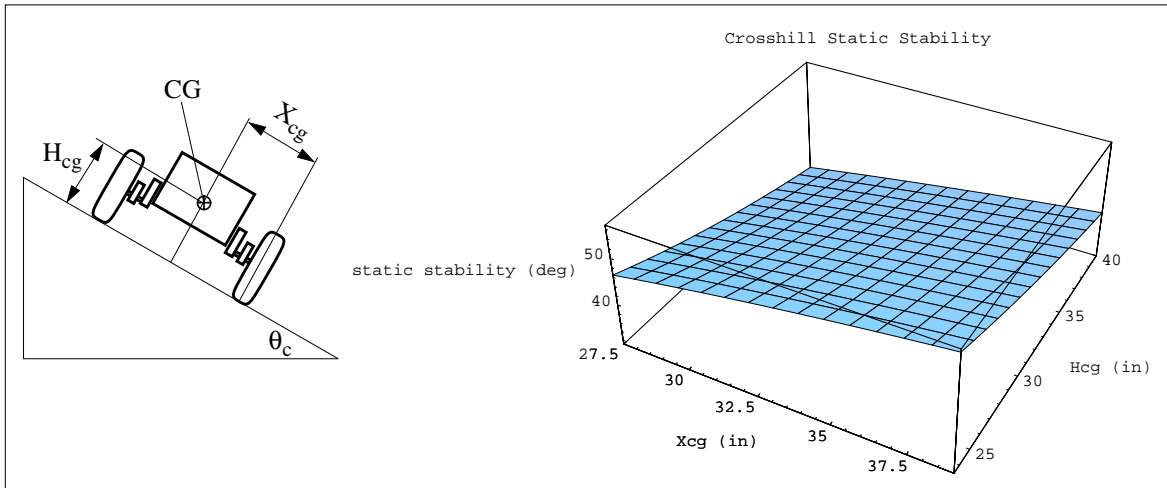
$$\theta_{d,max} = \text{atan}\left(\frac{y_{CG}}{h_{CG}} SM_{st}\right) \quad [\text{eq.A19}]$$



**Figure A-23:** Downhill gradability (max. slope in deg) as a function of the position of the center of gravity:  $Y_{cg}$  (in) and  $H_{cg}$  (in).  $SM_{st}$  is a static stability margin and is taken to be 10%.  $Y_{cg}$  is approximately equal to half the wheelbase.

- **Crosshill gradability based on static stability:**

$$\theta_{c, max} = \text{atan}\left(\frac{x_{CG}}{h_{CG}} SM_{st}\right) \quad [\text{eq.A20}]$$



**Figure A-24:** Crosshill gradability (max. slope in deg) as a function of the position of the center of gravity:  $X_{cg}$  (in) and  $H_{cg}$  (in).  $SM_{st}$  is a static stability margin and is taken to be 10%.  $X_{cg}$  is approximately equal to half the robot stance.

Mobility Analysis References: [Amai93], [Bekker56/60/64/69], [Boeing92], [JPL87], [Carrier92], [Klarer93], [Turnage87], [Wallace93], [Wong68], [Wong93].